

National Aeronautics and
Space Administration

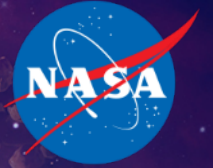

EXPLORE SOLAR SYSTEM & BEYOND

NASA Astrophysics Update

Paul Hertz

Director, Astrophysics Division, Science Mission Directorate

 @PHertzNASA

Astrophysics Advisory Committee

October 19, 2020

NASA SCIENCE

AN INTEGRATED PROGRAM



**EARTH
SCIENCE**



HELIOPHYSICS



**PLANETARY
SCIENCE**



ASTROPHYSICS



**BIOLOGICAL &
PHYSICAL SCIENCE**



**JOINT AGENCY
SATELLITE**

NASA SCIENCE MISSION DIRECTORATE

OFFICE OF THE ASSOCIATE ADMINISTRATOR (DA000)



ASSOCIATE ADMINISTRATOR
Thomas Zurbuchen



DEPUTY ASSOCIATE ADMINISTRATOR
Sandra Connelly

MARS SAMPLE RETURN PROGRAM OFFICE (DA050)

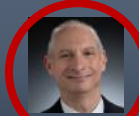

DIRECTOR
Jeff Gramling

NASA MANAGEMENT OFFICE (DA020)



DIRECTOR
Marcus Watkins



DEPUTY
Andrea Razzaghi

JAMES WEBB SPACE TELESCOPE OFFICE (DA010)



DIRECTOR
Greg Robinson



PROJECT MANAGER
Bill Ochs



SENIOR SCIENCE ADVISOR
Eric Smith

SCIENCE ENGAGEMENT & PARTNERSHIPS DIVISION (DO000)



DIRECTOR
Kristen Erickson

RESOURCE MANAGEMENT DIVISION (DL000)



DIRECTOR
Holly Degn

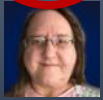

DEPUTY
Kate Wolf

MANAGEMENT

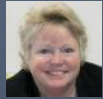

DEPUTY ASSOCIATE ADMINISTRATOR
Karen Flynn



ASSISTANT DEPUTY ASSOCIATE ADMINISTRATOR
Dan Woods

PROGRAMS



DEPUTY ASSOCIATE ADMINISTRATOR
Wanda Peters

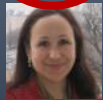

ASSISTANT DEPUTY ASSOCIATE ADMINISTRATOR
Mayra Montrose

RESEARCH



DEPUTY ASSOCIATE ADMINISTRATOR
Michael New

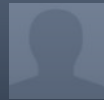

ASSISTANT DEPUTY ASSOCIATE ADMINISTRATOR
Vacant

EXPLORATION



Acting DEPUTY ASSOCIATE ADMINISTRATOR
Dave Burns

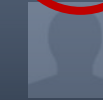

ASSISTANT DEPUTY ASSOCIATE ADMINISTRATOR
Vacant

ASTROPHYSICS DIVISION (DH000)



DIRECTOR
Paul Hertz



DEPUTY
Jeff Volosin



ASSOCIATE DIRECTOR
Jeanne Davis

BIOLOGICAL & PHYSICAL SCIENCES DIVISION (DP000)



DIRECTOR
Craig Kundrot



DEPUTY
Diane Malarik

EARTH SCIENCE DIVISION (DK000)



DIRECTOR
Karen St. Germain

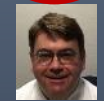

ASSOCIATE DIRECTOR
Charles Webb

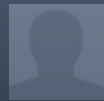

CHIEF SCIENCE DATA OFFICER
Vacant



DEPUTY
Sandra Cauffman



ASSOCIATE DIRECTOR
Jack Kay

HELIOPHYSICS DIVISION (DJ000)



DIRECTOR
Nicky Fox

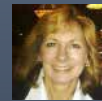

DEPUTY
Peg Luce

JOINT AGENCY SATELLITE DIVISION (DN000)



DIRECTOR
John Lee



DEPUTY
John Gagosian

PLANETARY SCIENCE DIVISION (DG000)



DIRECTOR
Lori Glaze



ASSOCIATE DIRECTOR
Joan Salute



DEPUTY
Eric Ianson



CHIEF MARS SCIENTIST
Michael Myer

Talk by Craig Kundrot on Day 1

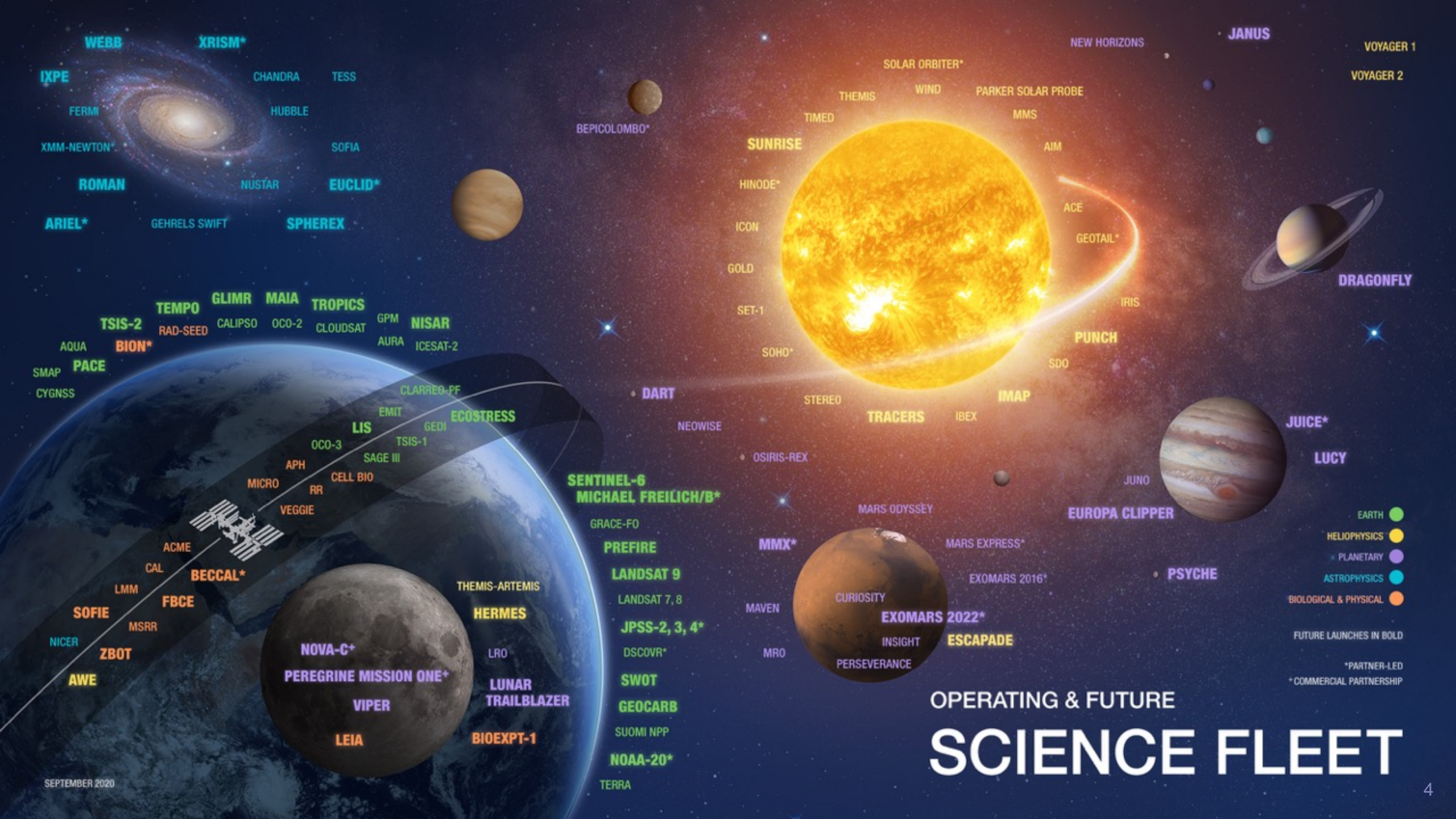

WEBB **XRISM***
IXPE **CHANDRA** **TESS**
FERMI **HUBBLE**
XMM-NEWTON* **SOFIA**
ROMAN **NUSTAR** **EUCLID***
ARIEL* **GEHRELS SWIFT** **SPHEREX**

TSIS-2 **GLIMR** **MAIA** **TROPICS**
TEMPO **RAD-SEED** **CALIPSO** **OCO-2** **CLOUDSAT** **GPM** **NISAR**
AQUA **BION*** **AURA** **ICESAT-2**
SMAP **PACE**
CYGNSS

CLARREO-PF **EMIT** **ECOSTRESS**
LIS **GEDI**
OCO-3 **TSIS-1**
SAGE III
APH **CELL BIO**
MICRO **RR** **VEGGIE**
ACME **BECCAL***
CAL **LMM** **FBCE**
MSRR
NICER **ZBOT**
AWE
NOVA-C* **HERMES**
PEREGRINE MISSION ONE* **LRO**
VIPER **LUNAR TRAILBLAZER**
LEIA **BIOEXPT-1**

SENTINEL-6 **MICHAEL FREILICH/B***
GRACE-FO
PREFIRE
LANDSAT 9
LANDSAT 7, 8
JPSS-2, 3, 4*
DSCOVR*
SWOT
GEOCARB
SUOMI NPP
NOAA-20*
TERRA

SOLAR ORBITER* **NEW HORIZONS** **JANUS** **VOYAGER 1**
THEMIS **WIND** **PARKER SOLAR PROBE** **VOYAGER 2**
TIMED **MMS**
SUNRISE **AIM**
HINODE* **ACE** **GEOTAIL***
ICON **IRIS**
GOLD **PUNCH**
SET-1 **SDO**
SOHO* **STEREO** **TRACERS** **IBEX** **IMAP**

DART **NEOWISE** **OSIRIS-REX** **JUNO** **JUICE*** **LUCY**
MARS ODYSSEY **EUROPA CLIPPER** **PSYCHE**
MMX* **MARS EXPRESS*** **EXOMARS 2016***
MAVEN **CURIOSITY** **EXOMARS 2022*** **ESCAPADE**
MRO **INSIGHT** **PERSEVERANCE**

- EARTH
 - HELIOPHYSICS*
 - PLANETARY
 - ASTROPHYSICS
 - BIOLOGICAL & PHYSICAL
- FUTURE LAUNCHES IN BOLD
 *PARTNER-LED
 + COMMERCIAL PARTNERSHIP

OPERATING & FUTURE SCIENCE FLEET



NASA's Mars 2020 Perseverance rover launched on the Atlas V-541 rocket from Launch Complex 41 at Cape Canaveral Air Force Station, Florida on July 30, 2020, at 7:50 a.m.



The Copernicus Sentinel-6 Michael Freilich satellite has passed all tests and is ready for shipment to the Vandenberg launch site in California.



SENTINEL-6

MICHAEL FREILICH



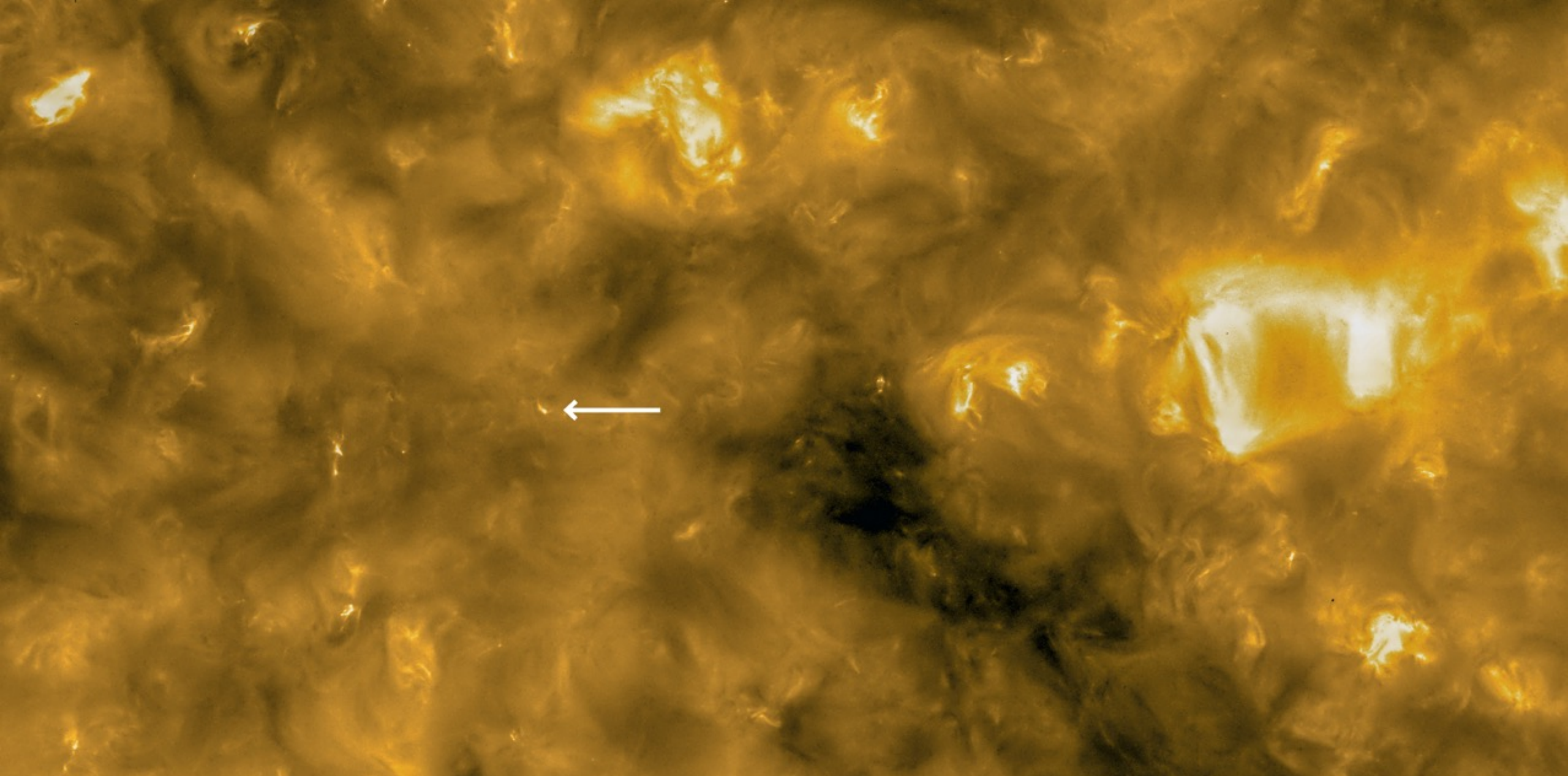

Solar Orbiter's first images were released to the public on Jul. 17, including the closest pictures ever taken of the Sun. Arrow points to "camp fires" actually nano flares, scattered across the Sun's surface.

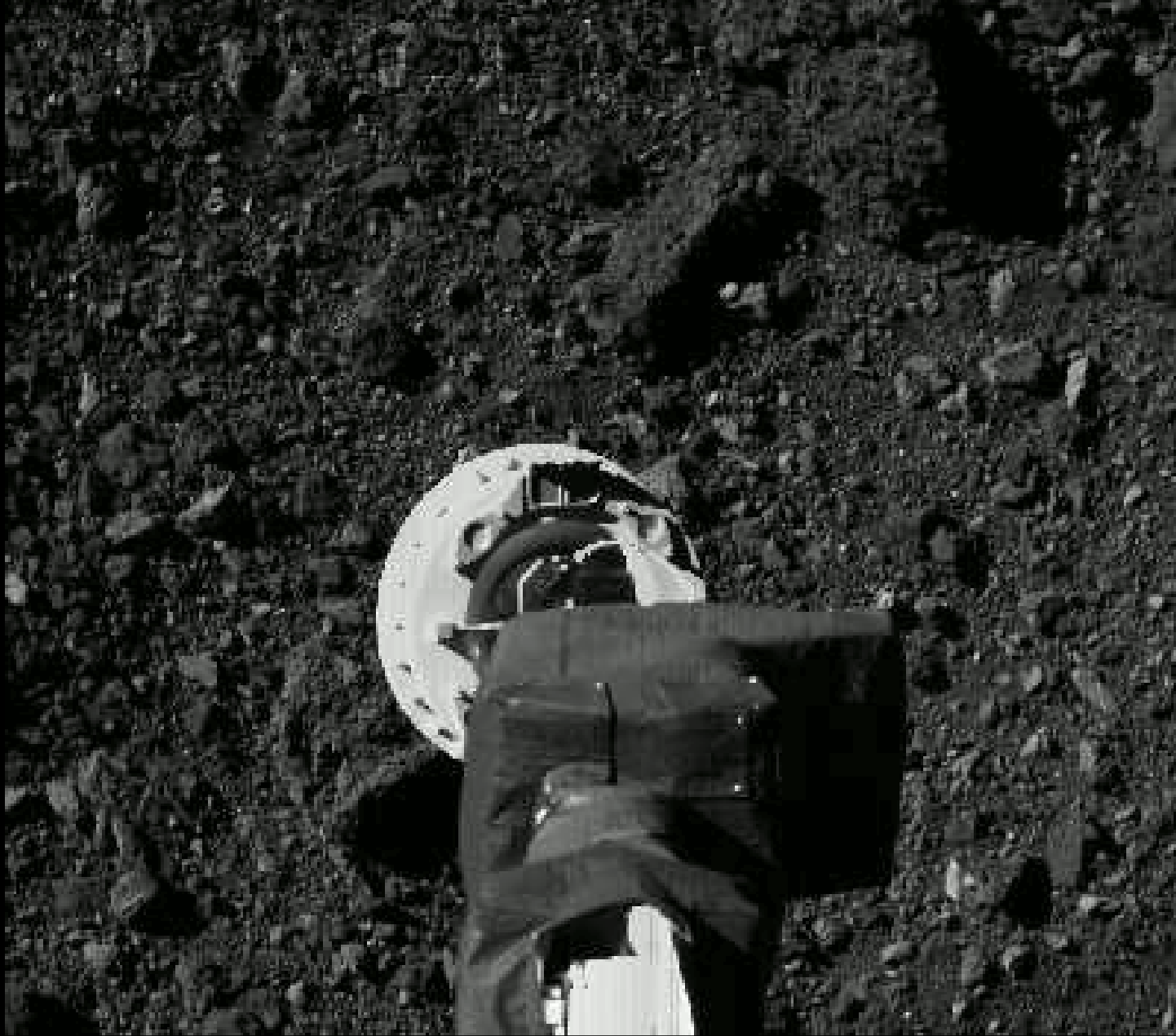

Asteroid 101955 Bennu

OSIRIS-REx performed final practice run of the sampling sequence on Aug 11, reaching approximate altitude of 40 meters over sample site Nightingale before executing a back-away burn. Sampling event (TAG) is on Oct. 20.



Webb Update by Eric Smith on Day 1

The James Webb Space Telescope is prepared for observatory-level environmental testing at Northrup Grumman Space Park in Redondo Beach, California. (left) Webb is lifted for transport. (right) Webb in the acoustic test chamber.



NASA Astrophysics Budget Update Happy New Fiscal Year 2021



Why Astrophysics?

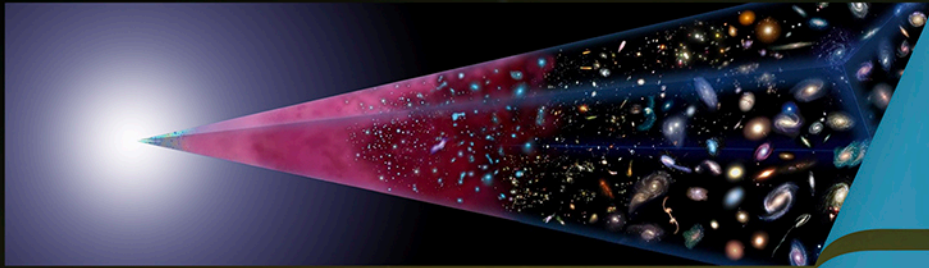

How did our universe begin and evolve?



How did galaxies, stars, and planets come to be?



Are we alone?

Enduring National Strategic Drivers

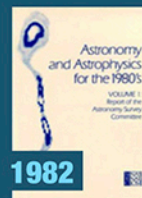

Astrophysics is humankind's scientific endeavor to understand the universe and our place in it.

Astrophysics Strategic Planning

<https://science.nasa.gov/astrophysics/documents>



Next update:
2021 Decadal Survey

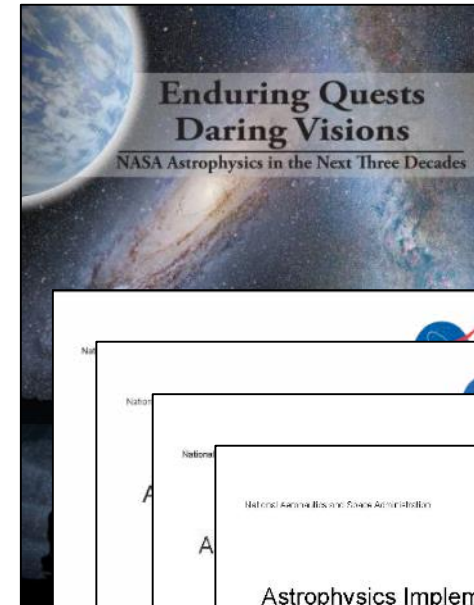

Next update:
December 2021
Implementation Plan

Astrophysics Budget – FY20 Plan

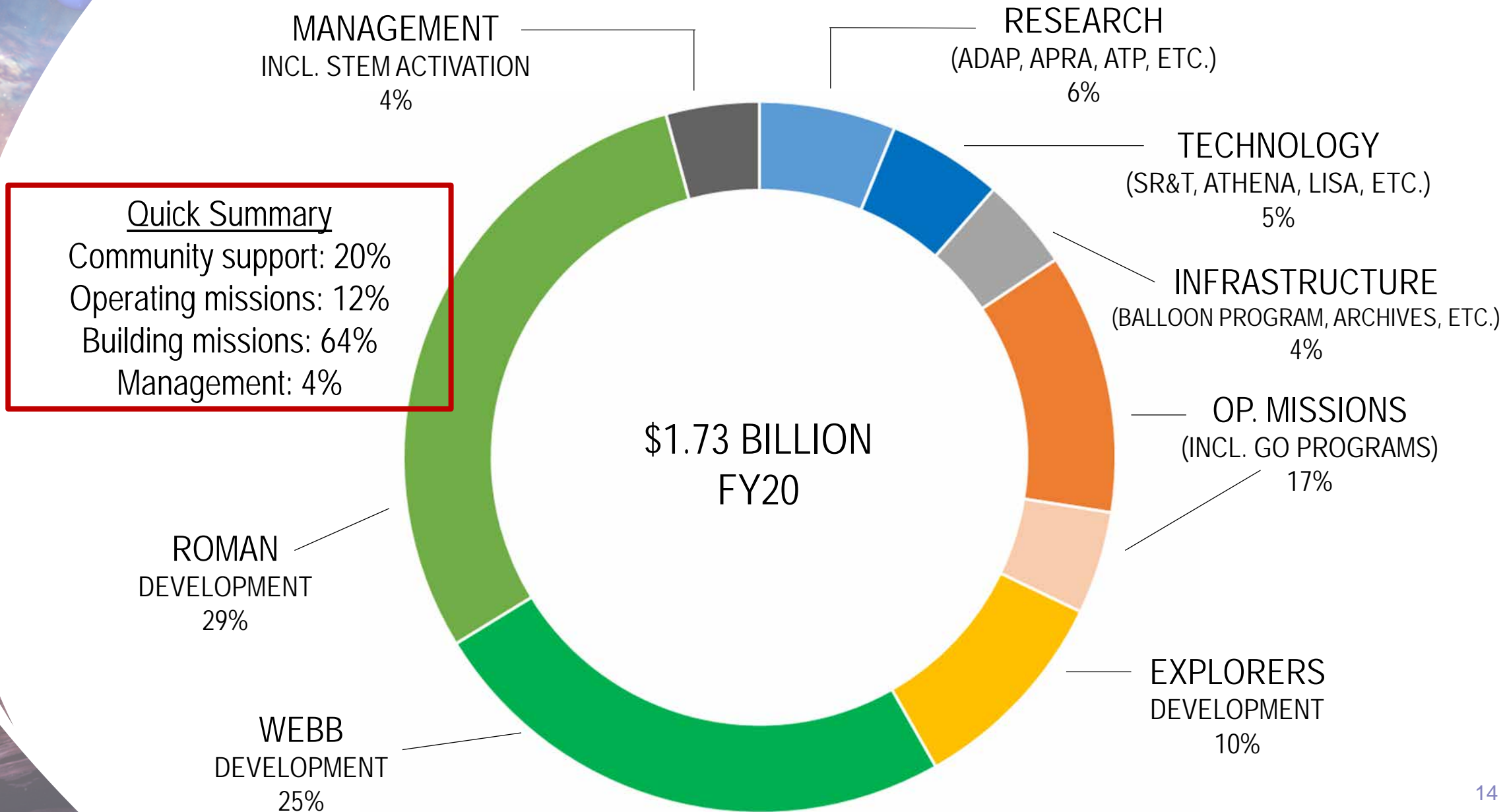

Astrophysics FY21 Budget Request



Supports Webb launch in 2021

Maintains decadal cadence of four AOs per decade for Astrophysics Explorers and Missions of Opportunity

Maintains healthy research program including CubeSats, suborbital missions, technology development, data analysis, theoretical and computational investigations, and laboratory astrophysics

Initiates new class of Astrophysics Pioneers: SmallSats and major balloon missions with reduced management overhead compared to traditional Astrophysics Explorers

Extends operating missions beyond FY20 with GO programs following 2019 Senior Review

Supports formulation of a probe mission as early as 2022

Supports mission concept studies and technology investments to implement Astrophysics Decadal Survey priorities starting in 2022

Terminates SOFIA due to high operating costs and lower science productivity to date

Given its significant cost and competing priorities within NASA, provides no funding for Roman Space Telescope

Astrophysics FY21 Budget Request

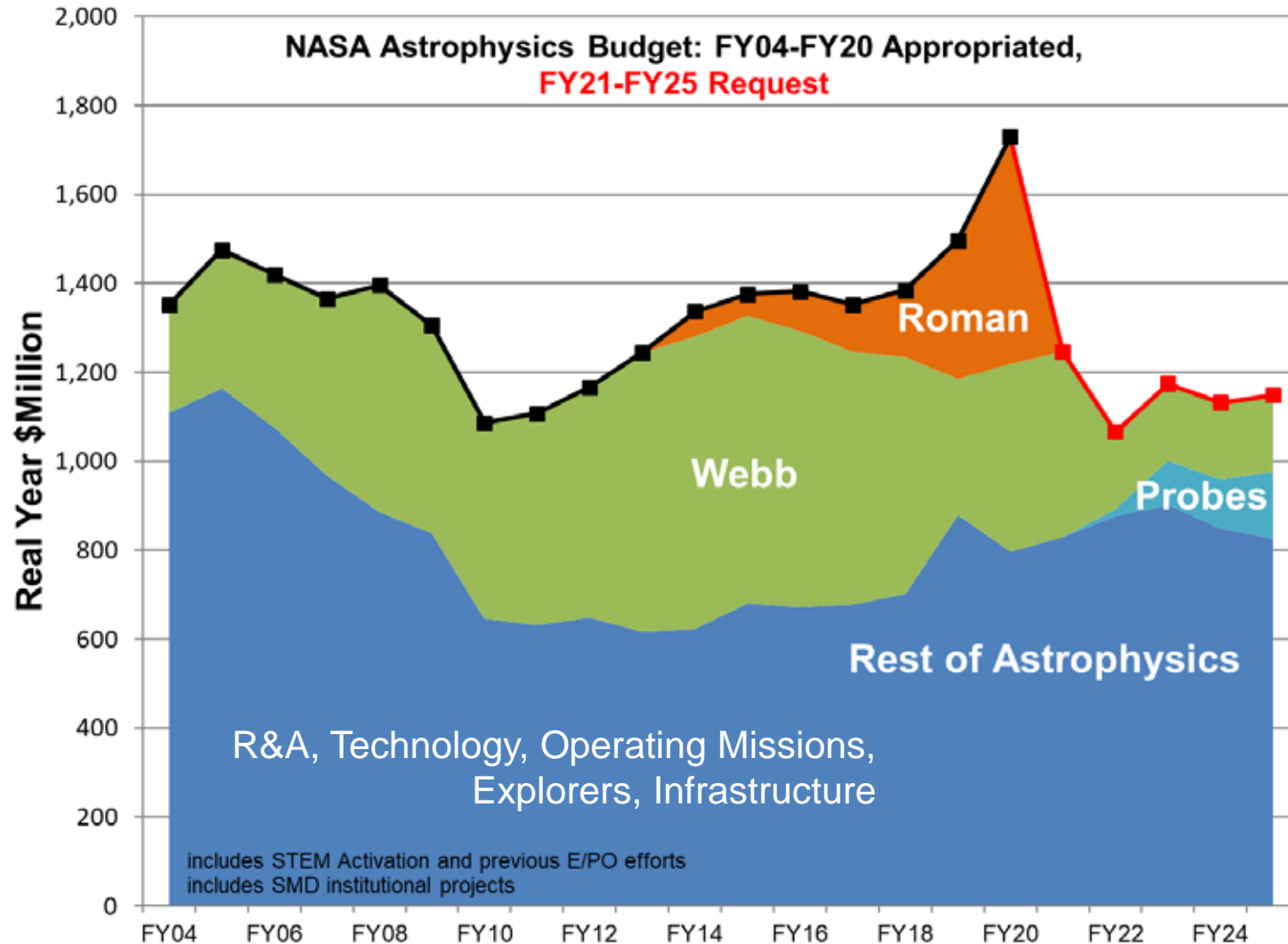

Astrophysics FY21 Budget Request

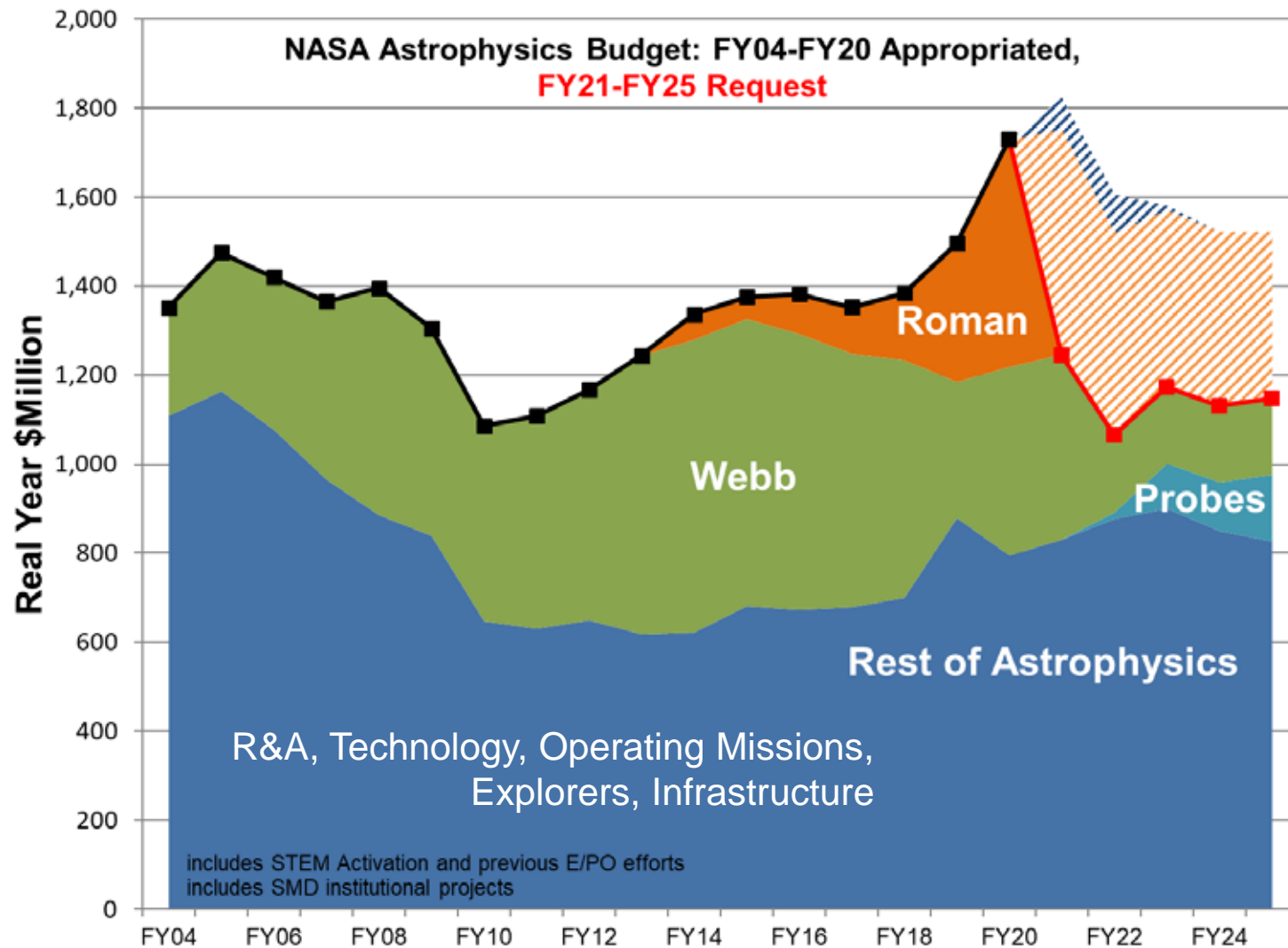

What if the Roman Space Telescope and SOFIA continue to receive appropriations?



Astrophysics FY21 Budget Request

Currently funded under a continuing resolution (CR) until December 11. All astrophysics programs and projects can continue as planned under the 11 week CR.

	Request (\$M)	Full Year CR or House Markup (\$M)	Comments
Astrophysics w/ Webb	1,245.7	1,729.2	FY20 appropriation is an increase of \$483.5M over FY21 request
Webb	414.7	423.0	FY20 appropriation is an increase of \$8.3M over FY21 request
Astrophysics	831.0	1306.2	FY20 appropriation is an increase of \$475.2M over FY21 request
Roman	0	505.2	Roman requirement in FY21 is an increase of \$505.2M over FY21 request
SOFIA	12.0	85.2	SOFIA historical appropriation is an increase of \$73.2M over FY21 request
Everything else	819.0	715.8	Continuing resolution requires a reduction of \$103.2M from FY21 request (planning budget)



COVID Impact Summary

All SMD missions in development continue to experience disruption due to COVID-related restrictions; we assume these disruptions will continue for the time being

At the portfolio level, SMD is taking short- and medium-term actions to mitigate COVID impacts in order to ensure mission success and overall portfolio health

Space operational missions continue science operations

- Balloon campaigns cancelled in 2020

- Sounding rocket launches suspended for six months, resumed in September

- SOFIA flights suspended for five months, resumed in August

Research & Analysis programs continue with COVID accommodations

- All peer reviews are virtual

- Funding continues to be provided

- Flexibilities granted to enable PIs and institutions to fund researchers

Loss of access to facilities and inefficiencies of research-from-home results in a true loss of science and research accomplishments

- NASA cannot assume that additional funding will be provided to recover lost science

- SMD is mitigating the impact on early career researchers within the existing budget



NASA Astrophysics Response to APAC Recommendations

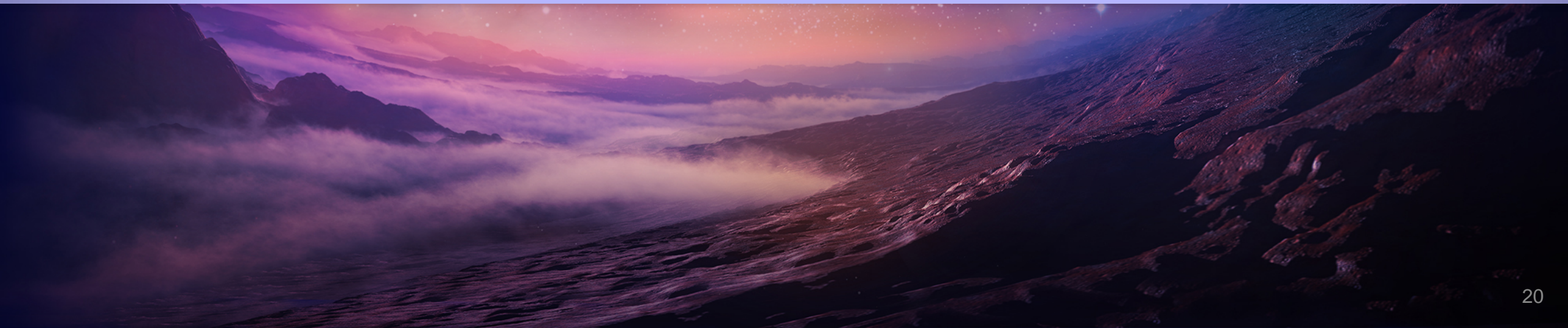

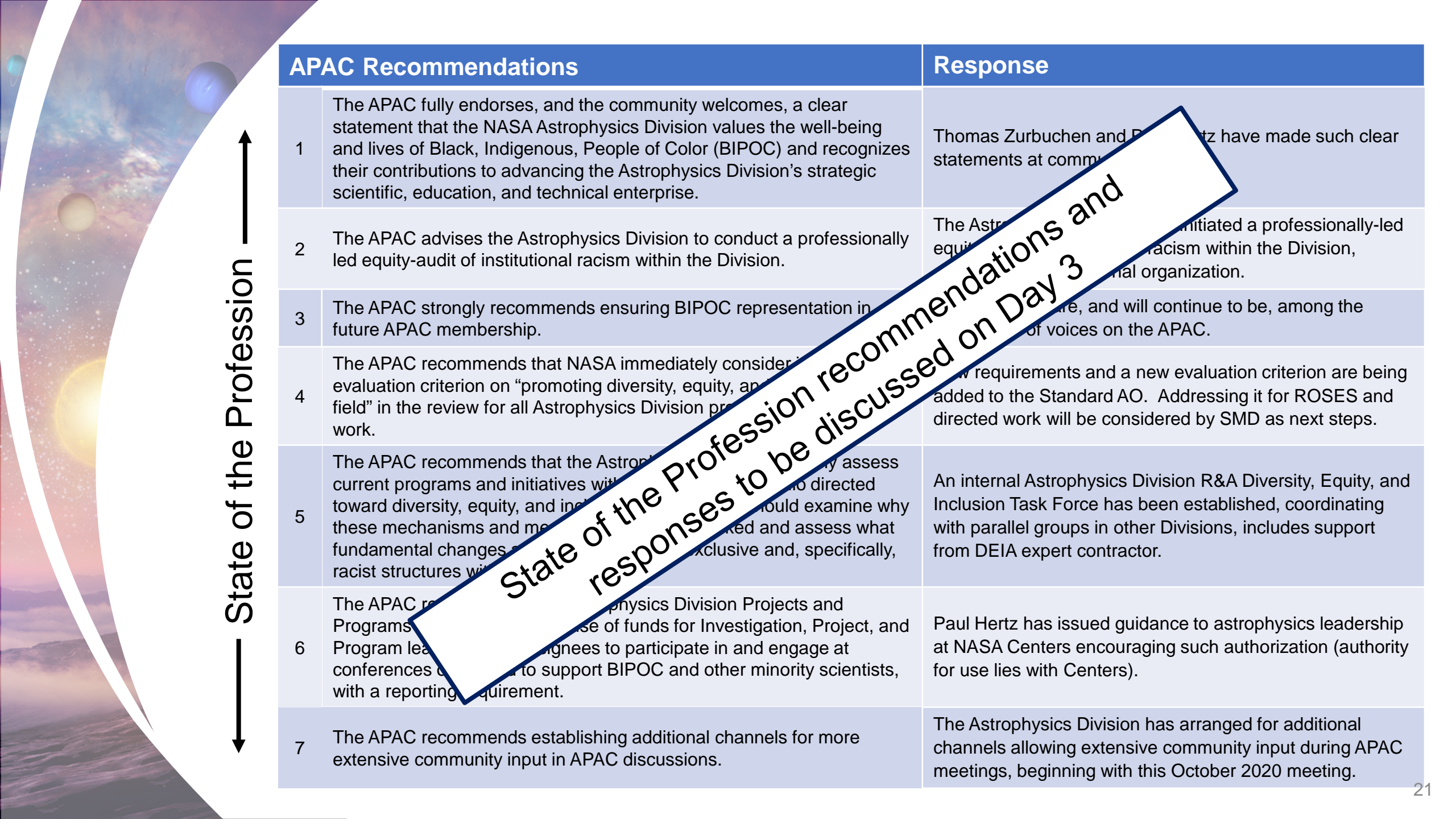

State of the Profession

APAC Recommendations		Response
1	The APAC fully endorses, and the community welcomes, a clear statement that the NASA Astrophysics Division values the well-being and lives of Black, Indigenous, People of Color (BIPOC) and recognizes their contributions to advancing the Astrophysics Division's strategic scientific, education, and technical enterprise.	Thomas Zurbuchen and Paul Hertz have made such clear statements at community meetings.
2	The APAC advises the Astrophysics Division to conduct a professionally led equity-audit of institutional racism within the Division.	The Astrophysics Division initiated a professionally-led equity-audit of institutional racism within the Division, and will continue to be, among the community organizations.
3	The APAC strongly recommends ensuring BIPOC representation in future APAC membership.	The Astrophysics Division will continue to be, among the community organizations, a source of voices on the APAC.
4	The APAC recommends that NASA immediately consider adding an evaluation criterion on "promoting diversity, equity, and inclusion in the field" in the review for all Astrophysics Division projects and programs.	New requirements and a new evaluation criterion are being added to the Standard AO. Addressing it for ROSES and directed work will be considered by SMD as next steps.
5	The APAC recommends that the Astrophysics Division assess current programs and initiatives with a focus on directed work toward diversity, equity, and inclusion. The Division should examine why these mechanisms and mechanisms are not working and assess what fundamental changes are needed to address and dismantle racist structures within the Division.	An internal Astrophysics Division R&A Diversity, Equity, and Inclusion Task Force has been established, coordinating with parallel groups in other Divisions, includes support from DEIA expert contractor.
6	The APAC recommends that the Astrophysics Division Projects and Programs Office increase the use of funds for Investigation, Project, and Program leadership to support BIPOC and other minority scientists, with a reporting requirement.	Paul Hertz has issued guidance to astrophysics leadership at NASA Centers encouraging such authorization (authority for use lies with Centers).
7	The APAC recommends establishing additional channels for more extensive community input in APAC discussions.	The Astrophysics Division has arranged for additional channels allowing extensive community input during APAC meetings, beginning with this October 2020 meeting.

State of the Profession recommendations and responses to be discussed on Day 3

APAC Recommendations		Response
8	The APAC requests brief update at next meeting on Artemis-inspired Commercial Lunar Payload Services (CLPS) astrophysics payloads selections.	Presentation by David Burns on Day 2
9	The APAC notes the dynamic nature of the exoplanet planet research program (XRP) driven by changes in the scope of proposals reviewed, as well as the sources of potential funding, and requests to be briefed on the current status of the process at the next meeting.	Presentation by Pamela Marcum on Day 2
10	The APAC requests additional briefings on potential implementation of actions contained within the Archive senior review.	Future meeting, plus a briefing on the SMD Data Initiative at a future meeting
11	The APAC requests the Astrophysics Division assess and to report out potential impacts on its mission if workforce constraints [recent Administration policy directives] are mandated and maintained over an extended period into the future.	On July 14, 2020, the Administration said it would no longer require foreign students to attend in-person classes during the coronavirus pandemic in order to remain in the country.
12	The APAC requests a detailed plan from the Astrophysics Division on the mechanisms that will be implemented to decide the missions that NASA will partner with and the instrumental contribution and the team that will lead the contribution.	Next chart
13	The APAC requests the Astrophysics Division clarify how US science investigators can join instrument teams, especially potential science team members from universities and institutions who are not part of NASA centers and facilities.	Next chart

Initiating Partnerships

Decision process for providing NASA contributions to partner-led missions

- Step 1: An idea is brought to SMD's attention
- Step 2: SMD ensures it has adequate information to consider the idea
- Step 3: SMD considers the idea
- Step 4: Path forward is discussed with the SMD AA
- Step 5: Preliminary response is given to the international partner
- Step 6: If needed, a joint study is conducted.
- Step 7: Final decision is made by SMD
- Step 8: If needed, acquisition strategy is decided and U.S. provider for the NASA contribution is selected (possibly through competition)

A SMD Policy Document is being developed to document the decision process

Process for US science investigators to join the mission science teams

- When appropriate, NASA will solicit proposals for the U.S. provider of the NASA contribution to an international mission
- NASA will issue open solicitations (generally through ROSES) to solicit the U.S. science team members of any international mission for which NASA is providing a contribution. Examples: Euclid (2012), XRISM (2017, 2021)
- NASA will regularly issue open solicitations (generally through ROSES) to solicit "USPI" proposals for U.S. investigators to join the science team of any international mission for which NASA is not providing a contribution

APAC Recommendations		Response
14	The APAC recommends the TORs for the proposed new ExoPAG SAG to the Astrophysics Division director for consideration and potential approval.	Approved by the Astrophysics Division Director
15	The APAC strongly recommends NASA reverse the decision to cancel the ADAP 2021 solicitation.	On June 26, 2020, NASA announced that ADAP will be solicited in 2021, thereby reversing the earlier decision.
16	The APAC advises the PAGS to provide a mechanism to collect public comments about Black, Indigenous, People of Color (BIPOC) issues, as the current public comment period during APAC meetings provides insufficient input from the community.	Presentation by Graça Rocha (PhysPAG) on Day 1; presentations by Margaret Meixner (COPAG) and Michael Meyer (ExoPAG) on Day 2
17	The APAC requests that the FMR and SOMER chairs and the SOFIA Science Mission (SMO) Director be present for an extensive question and answer session at its 2020 October meeting	Withdrawn by APAC
18	The APAC suggests that the SOFIA project develop strategies to achieve success during the next highly competitive NASA Astrophysics Division Senior Review (or similar process), given the current low number of papers and citations coupled with the significant operational costs.	The SOFIA project has developed such strategies. These strategies are described in the SOFIA Response to 5-Year Flagship Mission Review , and will be included in the revised SOFIA Project Plan.
19	The APAC requests a status updated on the COVID-19 induced Webb schedule re-plan and further clarification on the impacts of schedule erosion on the currently funded reserve resources .	Presentation by Eric Smith on Day 1

APAC Recommendations		Response
20	The APAC requests further information regarding plans for the US Athena data center when they become known.	NASA plans to compete the U.S. Athena Data Center at a TBD time in the future.
21	The APAC advises the Athena Project Scientist to discuss with the PhysPAG community the movement for "one-stop-shop" for X-ray data reduction for various missions.	The requirements for the U.S. Athena Data Center will be responsive to community needs and priorities. NASA welcomes input from the PhysPAG and from the U.S. Athena Science Team.
22	The APAC requests to be informed of the flight-testing progress of super-pressure balloon designs identified for use with GUSTO.	See next chart
23	The APAC requests future briefing on aspects of US community distribution and exploitation of CASE/ARIEL data products.	APAC will be briefed at a future meeting
24	The APAC requests a status on the identification of metrics associated with these programs at the next APAC meeting, and for the Science Activation Team to consider how to reach the broader community, including those without internet access, and to identify how to better coordinate with other existing NASA and Astrophysics Division activities.	See second chart

Qualification of the Super-Pressure Balloon

Pre-COVID-19 plan was to conduct two qualification flights of the super-pressure balloon (SPB) design before GUSTO launches on an SPB from Antarctica in December 2021

- Spring 2020 and Spring 2021 from Wanaka NZ

The Spring 2020 balloon campaign was cancelled in March 2020 due to COVID-19 restrictions

Current plan is to conduct one qualification flight of the SPB

- Spring 2021 from Wanaka NZ, if possible within COVID-19 restrictions
- Summer 2021 from Sweden, if New Zealand campaign cannot be conducted; the thermal environment of a Sweden launch, where the Sun is not setting on the balloon, is similar to the initial GUSTO SPB Antarctica launch environment

The use of a zero-pressure balloon (ZPB) for GUSTO is being studied as a backup

- Preliminary meteorological studies indicate that there is a high probability that GUSTO would attain its threshold requirements if launched on a ZPB
- ZPBs have less restrictive weather conditions for launch, so there are more launch opportunities in Antarctica for a ZPB than a SPB

Science Activation Metrics

- For the first phase of the Science Activation (SciAct) Program (2016-2020), each project reported metrics using a consistent format tied to top-level objectives (see APOD Astronomy Picture of the Day example). In addition, the Program as a portfolio reported metrics through the annual GPRAMA process (Active in all 50 states, Increase Partnerships, Increase Subject Matter Experts). For SciAct 2.0 (2021-2025), metrics will be aligned with mid-level objectives per the National Academies assessment and overseen by an independent portfolio evaluator.

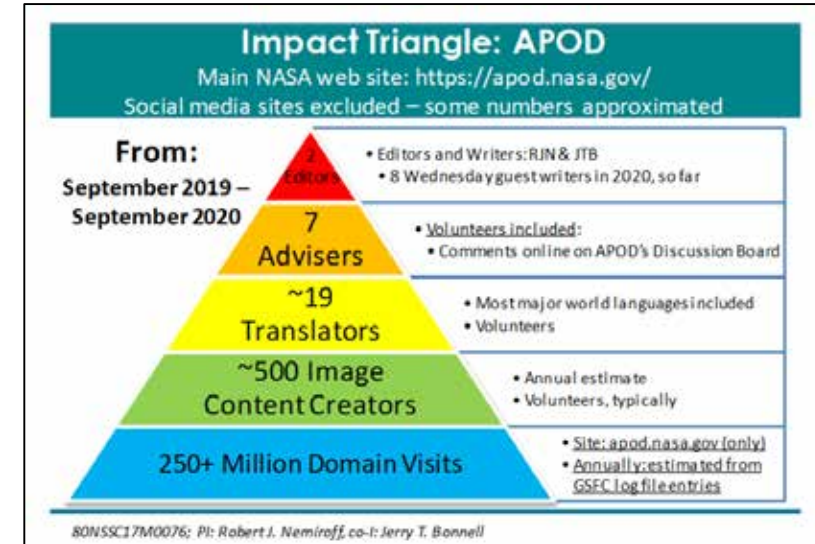

- SciAct funds two volunteer networks: Solar System Ambassadors (SSA) and Night Sky Network (NSN) that hold localized events (three/year) across the U.S. In 2020, NSN has held over 5500 live events to date – even with the pandemic. SSA just surpassed 50K events since 2016. In addition, SciAct has a “Rural Working Group” to implement the [2018 Federal Co-STEM strategy](#). STEM kits have been distributed to rural communities through our library network and to underserved BIPOC communities through our awardees and camp partnerships.
- Since the June 2020 APAC meeting, nine new awardees have been selected for five-year agreements, concentrating on broadening participation. The full list of new and extended awardees is available at <https://science.nasa.gov/learners>.



NASA Astrophysics Program Update Research & Analysis



Missions Spy First Possible 'Survivor' Planet Hugging White Dwarf Star

Released: September 16, 2020

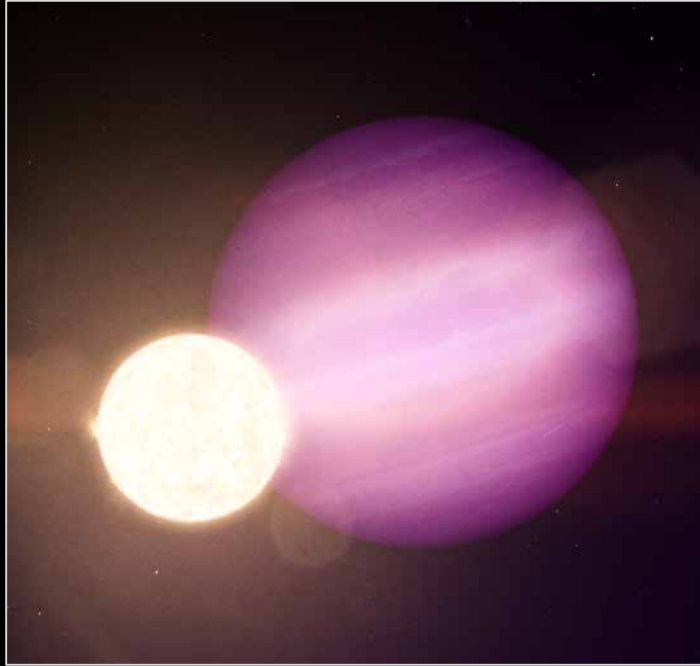

Artist Concept: NASA's Goddard Space Flight Center.

Caption: In this illustration, WD 1856 b, a potential Jupiter-size planet, orbits its much smaller host star, a dim white dwarf.

A. Vanderburg et al., <https://doi.org/10.1038/s41586-020-2713-y>

<https://www.nasa.gov/press-release/nasa-missions-spy-first-possible-survivor-planet-hugging-white-dwarf-star>



SCIENCE
HIGHLIGHT

- An international team of astronomers using NASA's Transiting Exoplanet Survey Satellite (TESS) and retired Spitzer Space Telescope has reported what may be the first intact planet found closely orbiting a white dwarf, the dense leftover of a Sun-like star.
- When a Sun-like star runs out of fuel, it swells up to hundreds to thousands of times its original size, forming a cooler red giant star. Eventually, it ejects its outer layers of gas, losing up to 80% of its mass. The remaining hot core becomes a white dwarf. Any nearby objects are typically engulfed and incinerated during this process.
- The white dwarf studied is named WD 1856+534, is roughly 11,000 miles (18,000 kilometers) across, may be up to 10 billion years old, and is a distant member of a triple star system.
- The Jupiter-size object that TESS and Spitzer found is called WD 1856 b. It is about seven times larger than the white dwarf. It circles this stellar cinder every 34 hours, more than 60 times faster than Mercury orbits our Sun. WD 1856 b is about 80 light-years away in the northern constellation Draco.
- The team suggests several scenarios that could have nudged WD 1856 b onto an elliptical path around the white dwarf. This trajectory would have become more circular over time as the star's gravity stretched the object, creating enormous tides that dissipated its orbital energy.

R&A Reviews since the Start of COVID-19

No solicitation was canceled due to COVID-19 and some due dates were postponed to give PIs more time.

R&A Review	Number of Proposals	Selection Rate	New PIs	PI Notification	Review Format	Comment
FINESST (Graduate Student Awards)	158	13%	N/A	108 days	Virtual	
TESS GI Cycle 3	155	32%	76%	137 days	Virtual	
NuSTAR GO Cycle 6	172	34%	39%	88 days	Virtual + dual anonymous	GO/GI dual anonymous pilot program
Fermi GI Cycle 13	109	38%	24%	126 days	Virtual	
Hubble GO Cycle 28	1,080	18%	33%	86 days	Virtual	
Chandra GO Cycle 22	520	31%	31%	132 days	Virtual	
Astrophysics SmallSat Studies	32	25%	100%	148 days	Virtual	
TCAN (Theory)	22	18%	100%	97 days	Virtual	
XRP (Exoplanets Research)	153	(pending)	(pending)	(pending)	Virtual	
ADAP (Data Analysis)	313	(pending)	(pending)	(pending)	Virtual + dual anonymous	R&A dual anonymous pilot program

Growth in R&A Funding

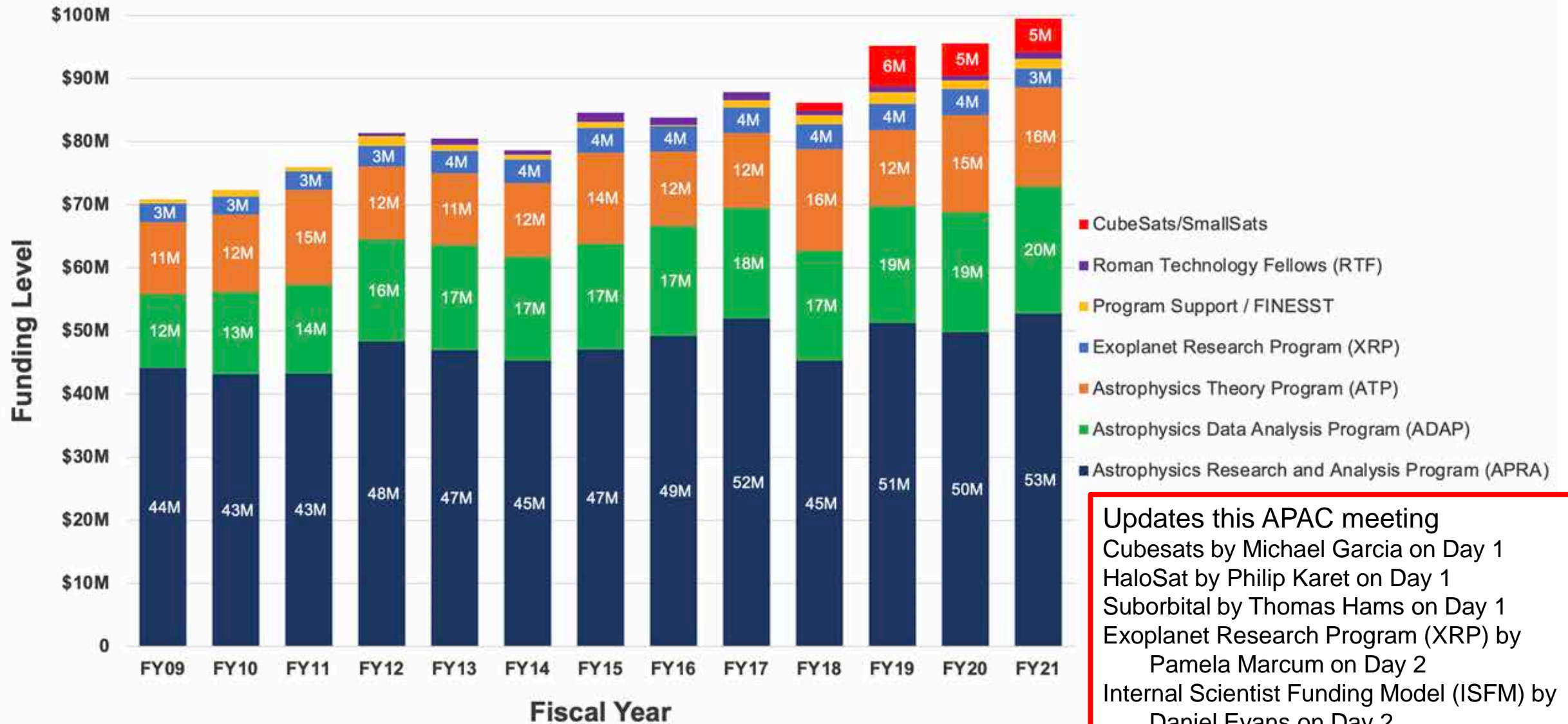

Updates this APAC meeting
 Cubesats by Michael Garcia on Day 1
 HaloSat by Philip Karet on Day 1
 Suborbital by Thomas Hams on Day 1
 Exoplanet Research Program (XRP) by Pamela Marcum on Day 2
 Internal Scientist Funding Model (ISFM) by Daniel Evans on Day 2
 Research Gaps by Kartik Sheth on Day 3

Astrophysics Community Funding

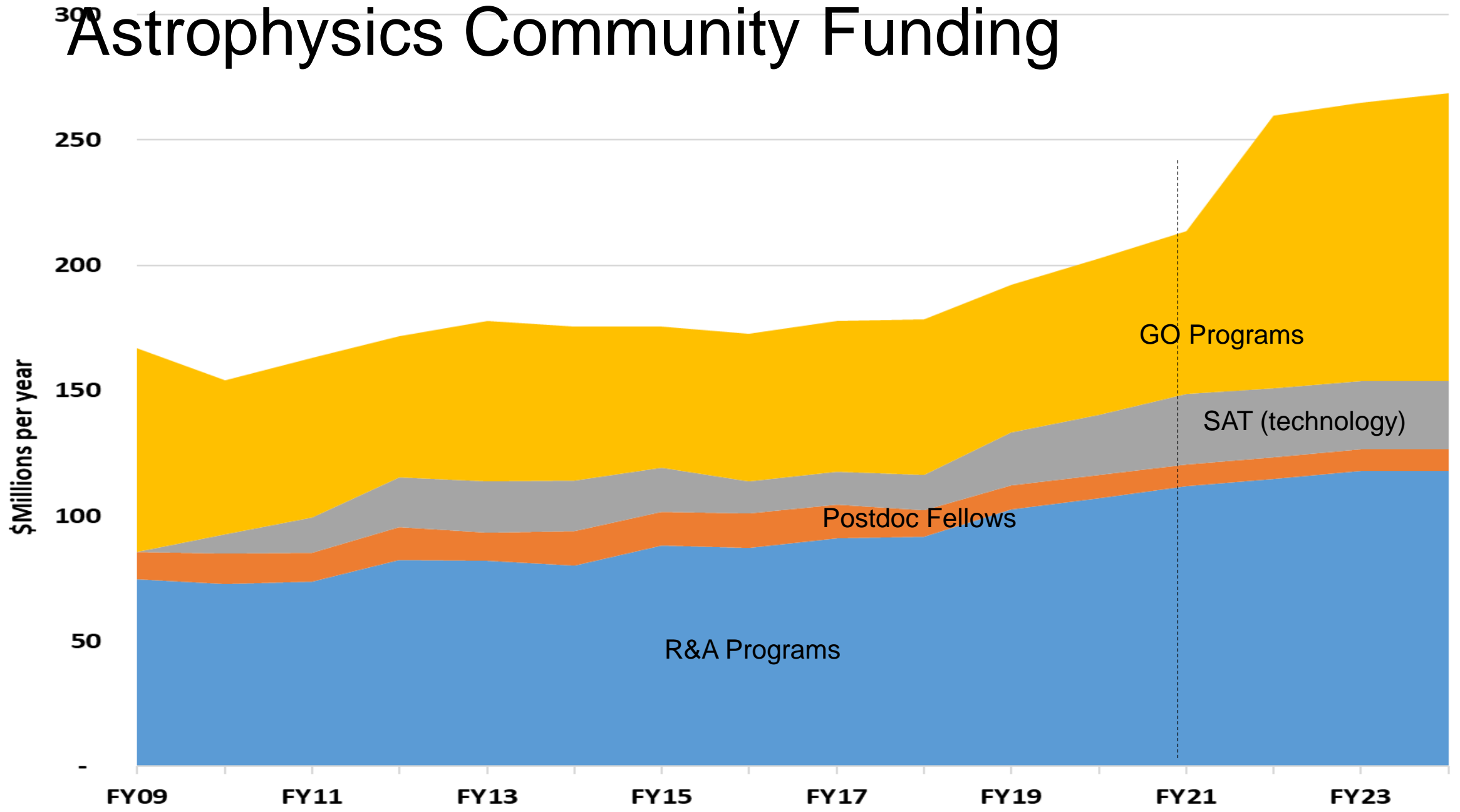

Increasing total R&A Funding

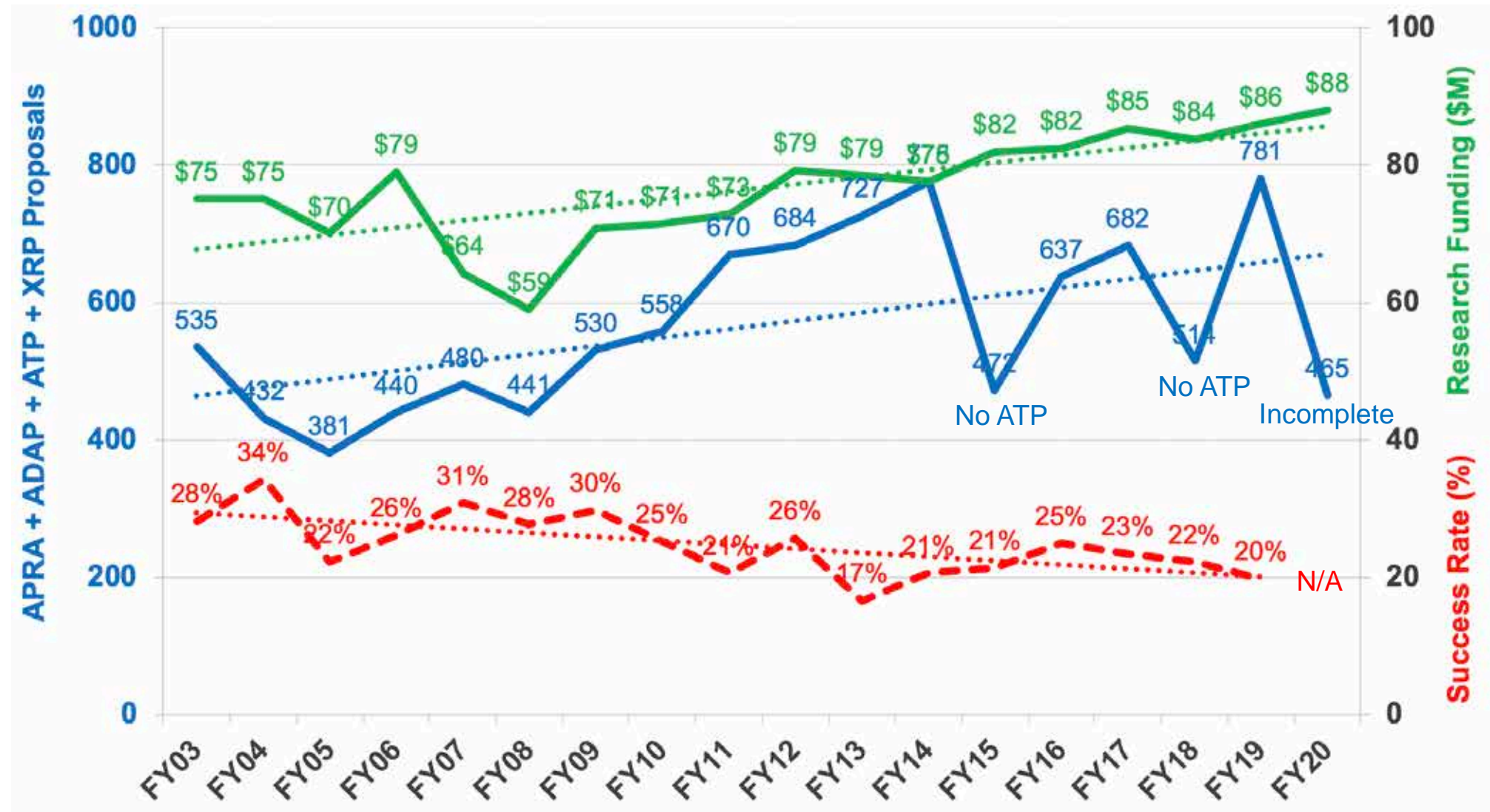

PI Notification in Days after Proposal Submission

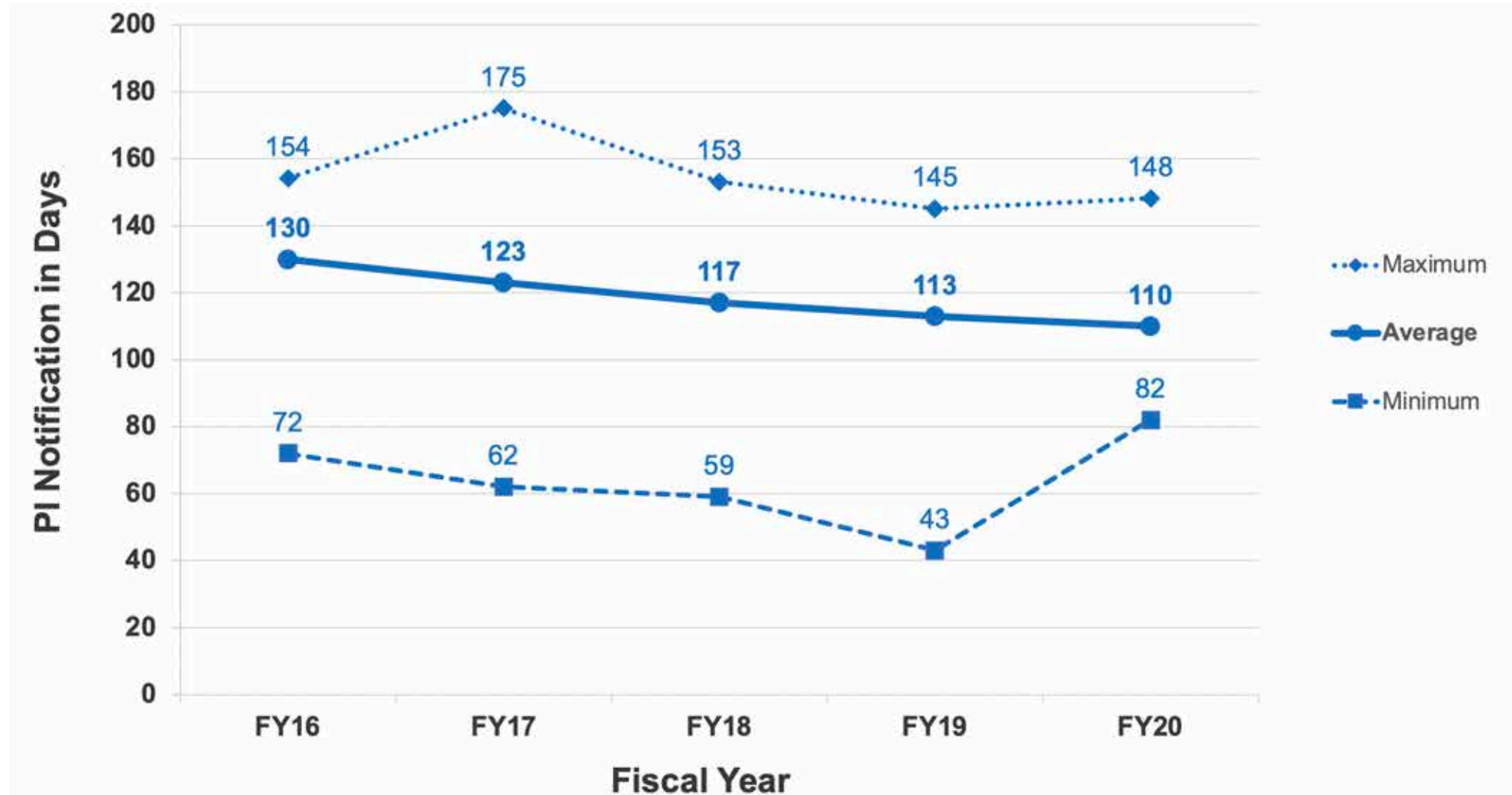



Extreme Precision Radial Velocity Foundation Science

- New R&A program element, amended to ROSES-20 on October 9 as Appendix D.17
- Responds to a recommendation in National Academies Exoplanet Science Strategy and the joint NASA/NSF Extreme Precision Radial Velocity (EPRV) Working Group
- Scope includes:
 - Studies of how stellar (including solar) surface phenomena and magnetic cycles impact radial velocity measurements based on disk-integrated spectra
 - Development of models, tools, and techniques for mitigating stellar radial velocity variability in disk-integrated spectra of stars
 - Evaluation of strategies for mitigating the effects of stellar variability and instrument systematics through cross-comparison of disk-integrated spectra of standard stars from different EPRV instruments
 - Development of advanced statistical methodologies to analyze complex radial velocity datasets to enable detection of small planets and precisely measure their masses
- Timeline of solicitation:
 - Step-1 Proposals due December 17, 2020
 - Step-2 (Full) Proposals due January 28, 2021
 - Selections announced in April 2021 (target)
 - 2-year awards fully funded in FY21. Total ~\$1.75M available

2021 Astrophysics Research Program Elements

ROSES-21:

Supporting Research and Technology

- Astrophysics Theory Program (ATP), every other year
- Astrophysics Research & Analysis (APRA)
- Strategic Astrophysics Technology (SAT)
- Roman Technology Fellowships (RTF)

Data Analysis

- Astrophysics Data Analysis (ADAP)
- GO/GI programs for Fermi, Swift, NuSTAR, TESS, NICER

Mission Science and Instrumentation

- Astrophysics Pioneers (suborbital science investigations)
- Suborbital payloads solicited through APRA
- XRISM Guest Scientist **New**

Cross Divisional

- Exoplanets Research Program (XRP)
- Topical Workshops, Symposia and Conferences (TWSC)
- Citizen Science Seed Funding Program **New**
- Graduate Student Research Awards (FINESST)

Not in ROSES-21:

Separately Solicited

- GO/GI/Archive/Theory programs for Hubble, Chandra, SOFIA, Webb
- NASA Hubble Fellowship Program (NHFP)
- NASA Postdoctoral Program (NPP)
- Support for XMM-Newton U.S. PIs selected by ESA

Not Solicited this Year

- Theoretical and Computational Astrophysics Networks (TCAN), every three years
- Astrophysics Explorers U.S. PIs (APEX USPI), every two to three years

2021 Astrophysics Research Program Elements

ROSES-21:

Supporting Research and Technology

- **Astrophysics Theory (ATP) - DAPR under consideration**
- Astrophysics Research & Analysis (APRA)
- Strategic Astrophysics Technology (SAT)
- Roman Technology Fellowships (RTF)

Data Analysis

- **Astrophysics Data Analysis (ADAP)**
- **GO/GI programs for Fermi, Swift, NuSTAR, TESS, NICER**

Mission Science and Instrumentation

- Astrophysics Pioneers (suborbital science investigations)
- Suborbital payloads solicited through APRA
- **XRISM Guest Scientist**

Cross Divisional

- **Exoplanets Research Program (XRP)**
- Topical Workshops, Symposia and Conferences (TWSC)
- Citizen Science Seed Funding Program
- Graduate Student Research Awards (FINESST)

Not in ROSES-21:

Separately Solicited

- **GO/GI/Archive/Theory programs for Hubble, Chandra, SOFIA, Webb**
- NASA Hubble Fellowship Program (NHFP)
- NASA Postdoctoral Program (NPP)
- Support for XMM-Newton U.S. PIs selected by ESA

Not Solicited this Year

- Theoretical and Computational Astrophysics Networks (TCAN), every three years
- Astrophysics Explorers U.S. PIs (APEX USPI), every two to three years

Red – evaluated using dual-anonymous peer reviews.

Theoretical & Computational Astrophysics Networks (TCAN 20)

Dynamical Instabilities in the Aid of Planet Formation in Circumstellar Disks

PI: Wladimir Lyra

New Mexico State U., Iowa State, SETI Inst., UNLV, U.

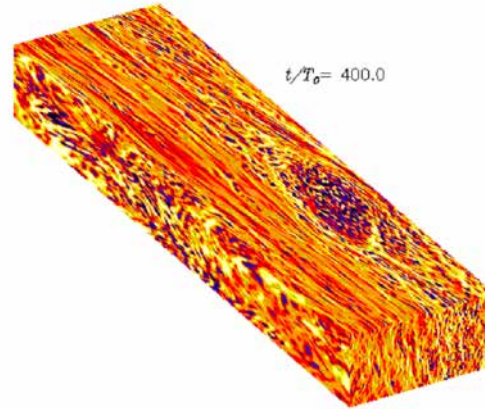

Global Models of Accretion and Outflows in Astrophys. Disks: A New DAWN (Disk Accretion & Winds Network)

PI: Daniel Proga

U. Nevada, Las Vegas, IAS, UVA, GSFC, CCA

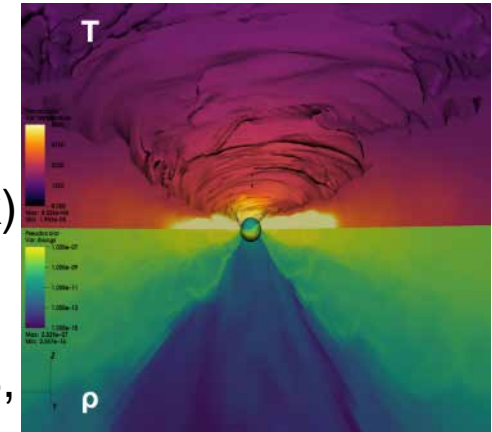

Simulating Cosmic Reionization Beyond the Current State-of-the-Art

PI: Nicolay Gnedin

U. Chicago, UC Santa Cruz, U. Pittsburg

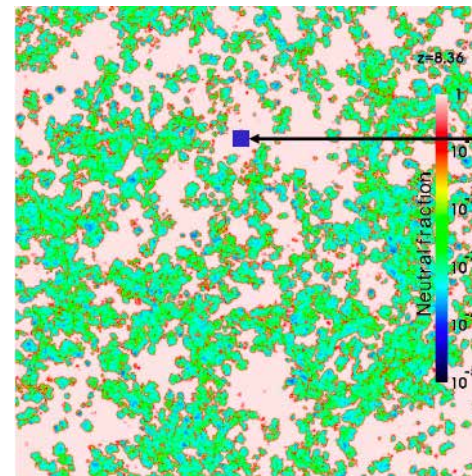

Gas and Galaxies Across Cosmic Time with Enzo-E

PI: Molly Peeples

Space Telescope Sci. Inst., Columbia, UCSD, MSU, Georgia Tech



Determining Unknown Yet Significant Traits (DUST)

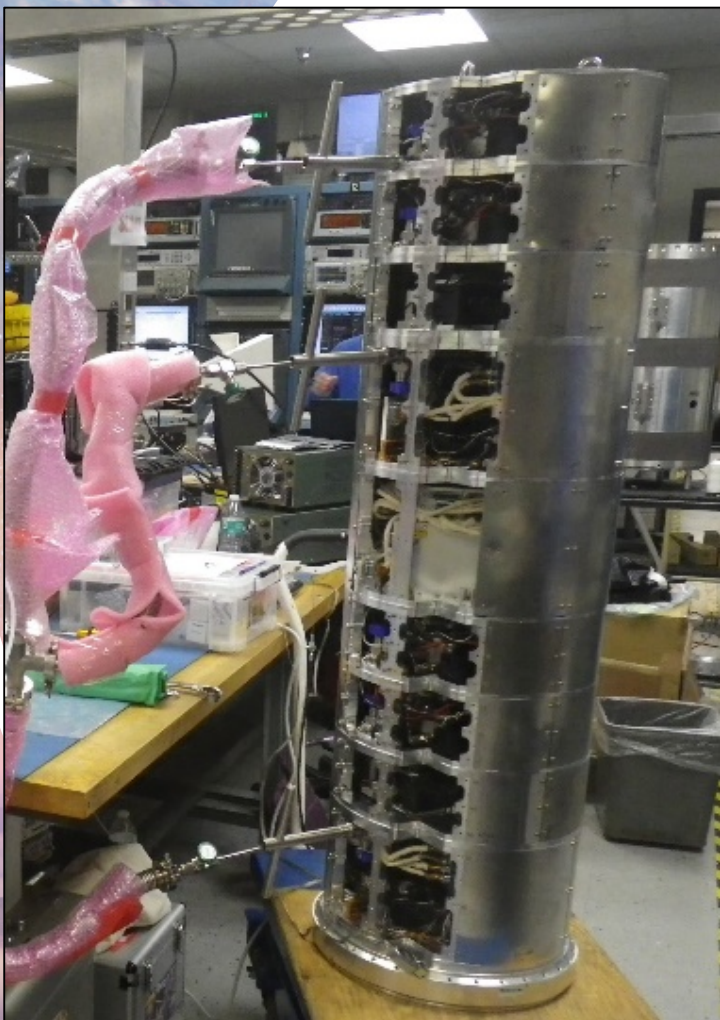

Rocket Payload during tests at WFF

- The DUST-2 mission (PI J. Nuth, GSFC) launched successfully from WSMR at 2:00 pm EST on September 8, 2020.
- First sounding rocket launch since COVID.
- Vehicle performed nominally. Five of six internal experiments functioned properly.
- This Lab Astro experiment will measure the spectrum and grain growth efficiency of silicates from the vapor phase at temperatures of stellar outflows.

Update by Thomas Hams
on Day 1

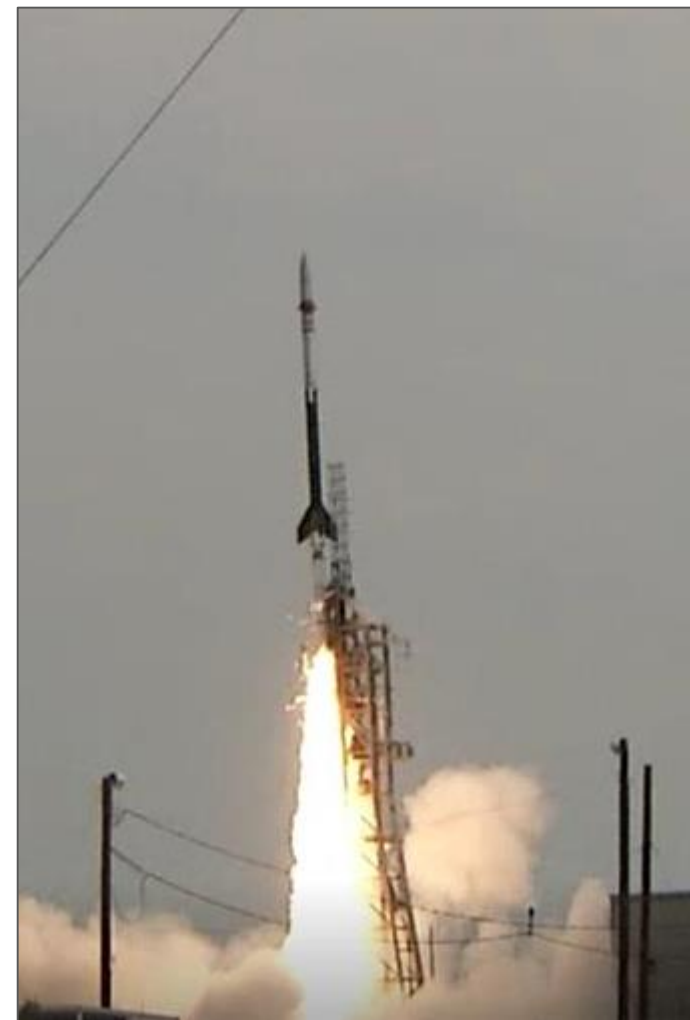

*Launch of DUST-2
Sep 8, 2020*

R&A Grant Extensions & Flexibilities

(COVID-19 mitigation)

SMD does not want the COVID-19 epidemic to derail the careers of future leaders; we continue to focus on mitigating the impacts of the epidemic

SMD Policy (SPD-36): Current grantees may request funded extensions from SMD

Highest priority for funding is to support graduate students and postdocs

Next highest priority is for funding to support early-career soft-money researchers

Due to budgetary limitations, proposals to support the completion of proposed research without any support for graduate students, post-docs, or early-career soft-money researchers shall not be considered

SMD will issue a ROSES call for funded extensions in the near future

This initiative must be funded from the R&A Program, size of commitment is expected to be approximately 15% of funding available for new awards in FY21

There will be 15% fewer new awards in FY21

Government-wide flexibility for paying salaries of researchers even if they could not work because of COVID expired on September 30. NASA has established a process to consider extending this flexibility to pay salaries on a case-by-case basis



<https://science.nasa.gov/researchers/covid-and-awards>



NASA Astrophysics Program Update Operating Missions



Astrophysics Missions in Operations

<p>Hubble ^{4/90} NASA Strategic Mission</p>  <p>Operations Nominal</p>	<p>Chandra ^{7/99} NASA Strategic Mission</p>  <p>Science Ops Resumed</p>	<p>XMM-Newton ^{12/99} ESA-led Mission</p>  <p>Operations Nominal (ESA)</p>	<p>Gehrels Swift ^{11/04} NASA MIDEX Mission</p>  <p>Operations Nominal</p> <p><i>Swift Update By Brad Cenko on Day 2</i></p>	<p>Fermi ^{6/08} NASA Strategic Mission</p>  <p>Operations Nominal</p>	<p>NuSTAR ^{6/12} NASA SMEX Mission</p>  <p>Operations Nominal</p>
<p>SOFIA ^{5/14} NASA Strategic Mission</p>  <p>Operations Restarted Aug 17 - Sep 29</p>	<p>ISS-NICER ^{6/17} NASA Explorers Miss. of Oppty</p>  <p>Operations Nominal</p>	<p>TESS ^{4/18} NASA MIDEX Mission</p>  <p>Operations Nominal</p> <p><i>TESS Update by Padi Boyd on Day 2</i></p>	<p>Balloon Program Four Campaigns per Year</p>  <p>Operations Suspended</p> <p><i>Balloon Roadmap Update by Peter Gorham on Day 1</i></p>	<p>Sounding Rockets Worldwide Campaigns</p>  <p>Operations Resumed Sep 8</p> <p><i>Suborbital Update by Thomas Hams on Day 1</i></p>	<p>Data Archives HEASARC, IPAC, MAST, etc.</p>  <p>Operations Nominal</p>

Hubble Space Telescope Update

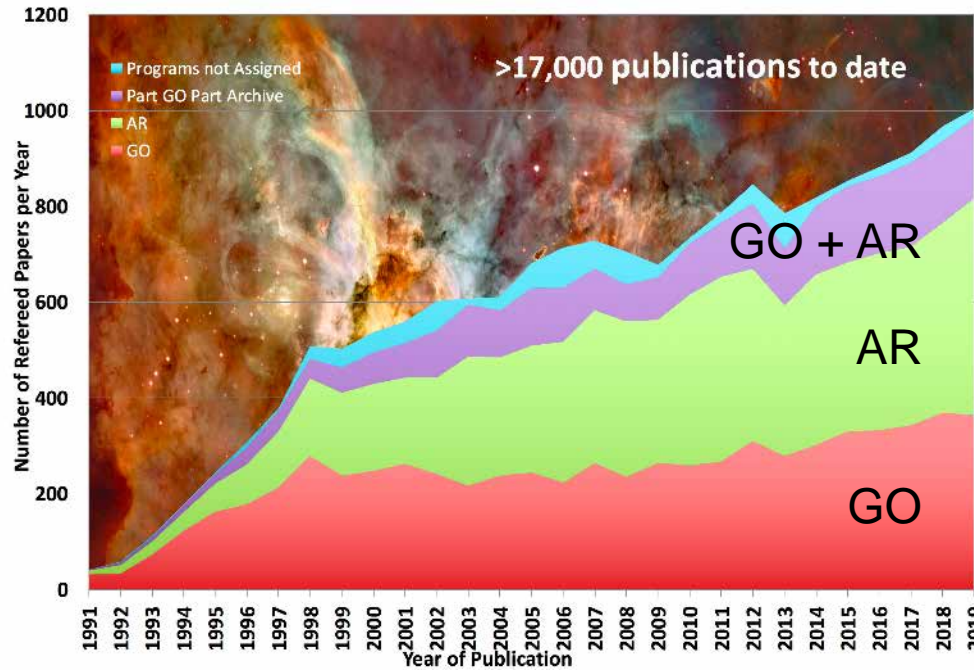

- Hubble continues to operate at peak scientific productivity 30 years after launch and 11 years after Servicing Mission 4
 - NASA planning for many more years of Hubble operations
 - Hubble orbit stable beyond 2030
 - Of the 6 new gyros installed in SM4, the three with 'enhanced flex leads' continue to operate
 - Operations can continue with a single gyro with slightly reduced efficiency
- STScI led the way with Dual Anonymous Peer Review in Hubble Cycle 26, Cycle 27 reviews
 - Resulted in a substantial increase in first time Hubble users
 - Resulted in an increase in female led projects
 - Resulted in an increase in proposals from a broader variety of institutions
 - Is now being adopted by numerous NASA programs

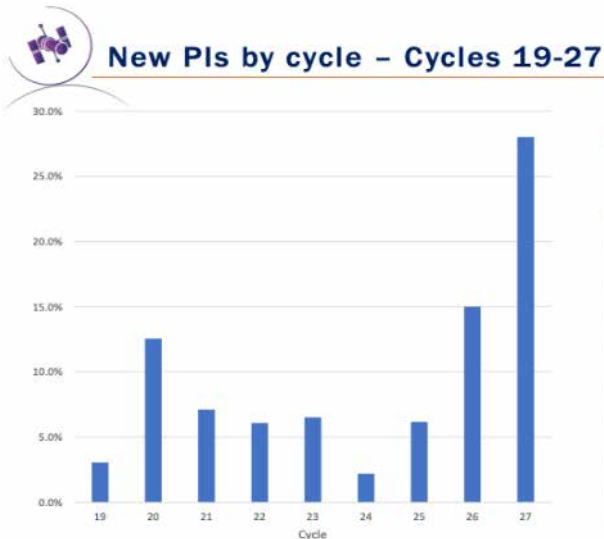

Congratulations to the Hubble Space Telescope Dual Anonymous Peer Review Team on being awarded a 2020 NASA Group Achievement Award

New Hubble Data Suggest There is an Ingredient Missing from Current Dark Matter Theories

Released: September 10, 2020

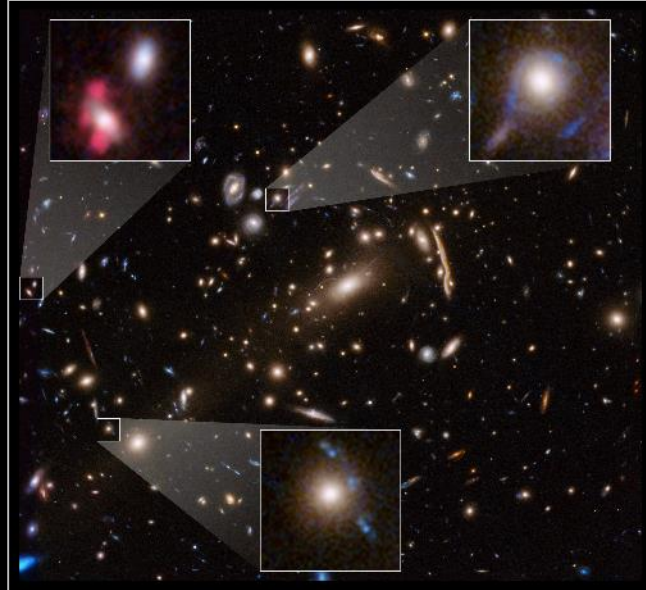

Image Credit: NASA, ESA, G. Caminha (University of Groningen), M. Meneghetti (Observatory of Astrophysics and Space Science of Bologna), P. Natarajan (Yale University), and the CLASH team.

Caption: This Hubble image shows the massive galaxy cluster MACSJ 1206. Embedded within the cluster are the distorted images of distant background galaxies, seen as arcs and smeared features. These distortions are caused by the dark matter in the cluster.

M. Meneghetti et al., <https://science.sciencemag.org/content/369/6509/1347>

<https://www.nasa.gov/feature/goddard/2020/hubble-observations-suggest-a-missing-ingredient-in-dark-matter-theories>



SCIENCE
HIGHLIGHT

- Observations by the Hubble Space Telescope and the European Southern Observatory's Very Large Telescope, in Chile, have found that something may be missing from the theories of how dark matter behaves.
- Dark matter is the invisible glue that keeps stars, dust, and gas together in a galaxy. This mysterious substance makes up the bulk of a galaxy's mass and forms the foundation of our Universe's large-scale structure.
- Because dark matter does not emit, absorb, or reflect light, its presence is only known through its gravitational pull on visible matter in space.
- Galaxy clusters are composed of individual member galaxies that are held together largely by the gravity of dark matter.
- The distribution of dark matter in clusters is mapped by measuring the bending of light — the gravitational lensing effect — that they produce. The gravity of dark matter concentrated in clusters magnifies and warps light from distant background objects. The higher the concentration of dark matter in a cluster, the more dramatic its light-bending effect.
- Researchers have uncovered an unexpected discrepancy between observations of the dark matter concentrations in a sample of massive galaxy clusters and theoretical computer simulations of how dark matter should be distributed in clusters.
- The new findings indicate that some small-scale concentrations of dark matter produce lensing effects that are 10 times stronger than expected.

Chandra X-ray Observatory

- On August 24 the High Resolution Camera (HRC) experienced an anomaly that was isolated to the A-side electronics, in use since launch in 1999. Science payloads were powered off during analysis.
- Activation of backup electronics, power on of the HRC shield, and confirmation of shield performance led to the Advanced CCD Imaging Spectrometer (ACIS) being powered back on September 11.
- Resumed full schedule of science observations on September 12 using ACIS only, which is utilized for about 95% of Chandra observations. A series of HRC operational tests and analysis started on September 29 and will continue for up to several weeks.



Dr. Patrick Slane was selected as the third Chandra X-ray Center Director and successor to Dr. Belinda Wilkes. Dr. Slane assumed his new role on September 25, 2020.

https://www.nasa.gov/mission_pages/chandra/news/update-on-chandra-x-ray-observatory-anomaly.html

TESS began extended mission July 5

Update by Padi Boyd on Day 2

336 publications submitted, 267 peer-reviewed
(51% exoplanets, 49% astrophysics)



TESS has discovered 67 confirmed planets and 2174 planet candidates

50 new exoplanets found in the Kepler data through an Artificial Intelligence /Machine Learning methodology

The total number of known confirmed exoplanets is now 4277

<https://heasarc.gsfc.nasa.gov/docs/tess/>
<https://tess.mit.edu/>
<https://archive.stsci.edu/tess/>

A New Planet on the Lower Edge of the Hot Neptune Desert: TOI-824 b

Burt et al, 2020

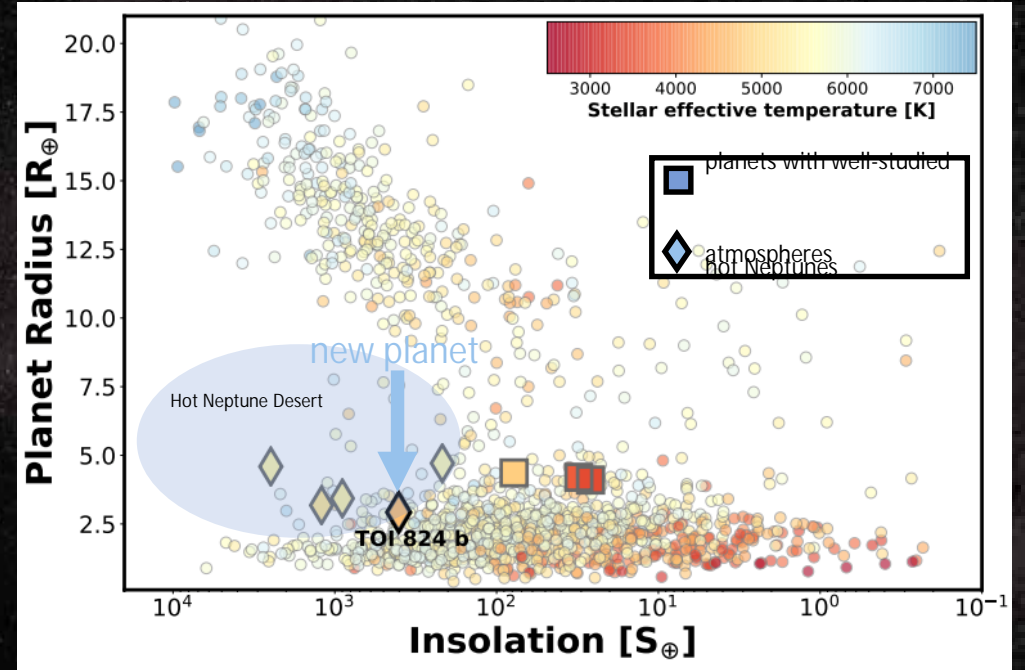

“hot Neptune desert” is the dearth of planets the size and mass of Neptune on periods shorter than 4 days

TOI-824 b has a precise mass and likely a cloud-free atmosphere, making it a promising target for the detection of atmospheric escape

SOFIA

Magnetic Field May Be Keeping Milky Way's Black Hole Quiet

<https://www.nasa.gov/feature/magnetic-field-may-be-keeping-milky-way-s-black-hole-quiet>



Hubble image of
Milky Way Center

SOFIA image of
dusty ring

SOFIA image of
tilted disk of hot gas

SOFIA image of
warm material falling
onto black hole

SOFIA image of hot
material falling onto
black hole

SOFIA image of
magnetic fields
channeling material

SOFIA Returns to Science in the COVID Era

After resuming operations on August 17th, SOFIA flew 15 successful science flights using two instruments. During these missions, SOFIA conducted a variety of investigations:

- SOFIA measured the magnetic field directions of dark molecular filaments, birth sites of stars.
- SOFIA measured the magnetic field structure in nearby galaxies to determine to what degree the magnetic field on larger scales follows the large-scale spiral arms.
- SOFIA made long observations of galaxies to measure atomic fine-structure lines to trace the distribution of cold and ionized gas,

SOFIA was ferried to Germany on September 29-30 for a major regular maintenance downtime.

SOFIA has published its plan to implement the recommendations from the 2019 reviews:

<https://www.sofia.usra.edu/science/sofia-overview/steering-documents>

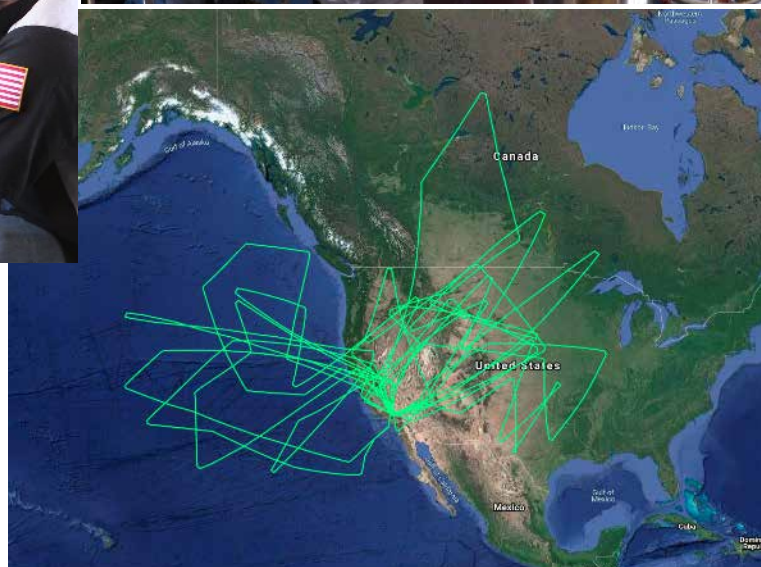

Flight paths of the 15 science flights



SOFIA arrived in Hamburg, Germany for the C-check on September 30, 2020.

<https://www.sofia.usra.edu/>



NASA Astrophysics Program Update Missions in Development



Astrophysics Missions in Development

Webb 2021
NASA Mission

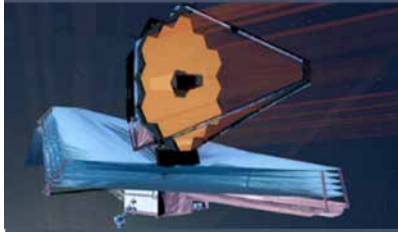

James Webb
Space Telescope

IXPE 2021
NASA Mission



Imaging X-ray
Polarimetry Explorer

GUSTO 2021
NASA Mission

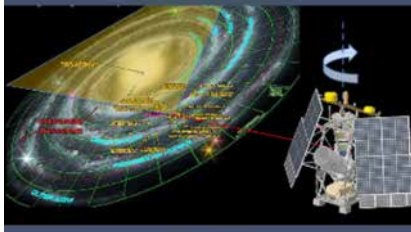

Galactic/ Extragalactic ULDB
Spectroscopic Terahertz Observatory

XRISM 2022
JAXA-led Mission



NASA is supplying the SXS
Detectors, ADRs, and SXTs

Euclid 2022
ESA-led Mission



NASA is supplying the NISP
Sensor Chip System (SCS)

SPHEREx 2024
NASA Mission



Spectro-Photometer for the History of
the Universe, Epoch of Reionization,
and Ices Explorer

SMEX ~2025
NASA Mission



COSI or ESCAPE

Mission of Opportunity ~2025
NASA Mission



Dorado or LEAP

Roman 2025
NASA Mission



Nancy Grace Roman
Space Telescope

ARIEL 2028
ESA-led Mission



NASA is supplying the CASE
fine guidance instrument

Launch dates are current project working dates; Agency Baseline Commitment launch date could be later; impacts of COVID-19 not yet known

Status of SMD Missions in Development

All SMD missions in Formulation are proceeding and missions in Implementation are accomplishing hands-on work. However, SMD continues to experience disruption to all missions due to COVID-related restrictions; we assume these disruptions will continue for the time being

- Reduced efficiency achieved at work sites and for those working from home, which includes reduced availability of workforce and reduced leave usage

- Travel restrictions, reduced availability of NASA facilities

- Disruptions to supply chain for current and future procurements

At the portfolio level, SMD is considering a series of short- and medium-term actions to mitigate COVID impacts in order to ensure mission success and overall portfolio health

- Within current budget, the use of HQ-held reserves and/or adjustment of launch date are being employed

- Where additional funds are necessary, SMD will consider delays or cancellations to planned missions in order to restore overall portfolio risk to acceptable levels

Life Cycle Reviews (LCR) and some Key Decision Points (KDPs) have continued to virtually report

- Some challenges/limitations have been observed in the LCR virtual environment regarding the ability of the review team members to have in-depth sidebar conversations

COVID Impacts to Astrophysics Missions in Development

Missions are in launch date order

Webb	Launch delay, cost impacts within reserves, replan approved July 2020
IXPE	Launch delay, KDP-D November 2020
GUSTO	Balloon program impact delays certification of super-pressure launch vehicle
XRISM	JAXA announced launch delay
Euclid	ESA maintaining schedule
SPHEREx	Schedule and cost impacts likely, KDP-C December 2020
SMEX/MO	Phase A extended, further schedule and cost impacts TBD, KDP-B (downselect) late summer 2021
Roman	Schedule and cost impacts likely, mission CDR 2021
ARIEL	Too early to tell, KDP-C Fall 2022
Athena	Too early to tell, KDP-A 2021
LISA	Too early to tell, KDP-A 2022

Many missions' launch delay and cost impacts may be covered within project and HQ-held reserves



The Webb observatory on the vibration table in Redondo Beach, CA in September 2020

Webb

The James Webb Space Telescope



- Observatory has completed final environmental testing
- COVID induced work inefficiencies and inclusion of as-performed time spans for deployment activities moved the launch date from March to October 2021
- Numerous launch and commissioning exercises occurring through the year at STScI with social distancing protocols in place
- Cycle 1 proposals due 24-Nov-2020
- Launch Readiness Date 31-October-2021

Webb Update by Eric Smith on Day 1

MMA 24 X-ray shells
edge-on front view

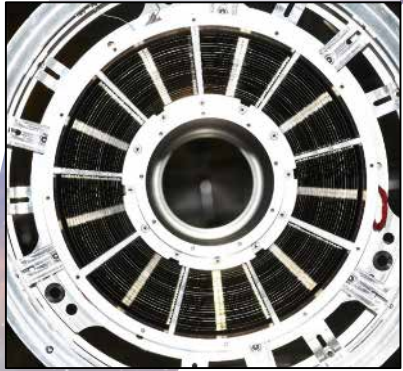

IXPE – Imaging X-ray Polarimetry Explorer

- Systems Integration Review (SIR) was successfully completed Sept. 22-24, 2020.
- KDP-D is planned for Nov. 2, 2020.



*MMA X-ray telescopes
boxed for shipment*



MMA X-ray telescope



Image courtesy of Ball Aerospace

MMA X-ray telescopes at Ball Aerospace



Image courtesy of Ball Aerospace

Astrophysics and Artemis



Artemis enables astrophysics

- All science opportunities enabled by Project Artemis include astrophysics
- Most important criterion for proposals remains the astrophysics science merit

There are many opportunities to propose astrophysics that uses Artemis capabilities

- Lunar surface astrophysics experiments can be proposed to the PRISM program of small landed payloads (in ROSES)
 - The recent call for PRISM experiment white papers included ~10 proposed astrophysics experiments
 - Two landed astrophysics experiments have been selected and manifested:
 - ∅ Low-frequency Radio Observations from the Near Side Lunar Surface instrument (PI: R. MacDowall, GSFC); manifest through CLPS Task Order 2 on Intuitive Machines Lander for NET October 2021
 - ∅ Next Generation Lunar Retroreflectors (PI: D. Currie, University of Maryland); to be manifest through CLPS Task Order 19D for early/mid 2023
- Astrophysics Explorers Mission of Opportunity calls (including 2019 Explorers MO and 2021 Explorers MO) allow proposals for cislunar smallsat missions
- APRA calls (in ROSES) allow proposals for cislunar cubesats

Astro2020 Decadal Survey will include any compelling astrophysics that is a high priority and is enabled by the capabilities being developed within the Artemis program

NASA participation in UltraSat

- NASA is joining Israel's UltraSat mission
- UltraSat: a wide-field (>200 sq deg) UV survey & transient detection mission from the Israel Space Agency & Weizmann Institute of Science
 - 50 cm diameter primary mirror
 - Camera contributed by DESY in Germany
 - Launch NET late 2024 for a 3-year mission
- Science: gravitational wave sources, supernovae, variable and flare stars, time domain astronomy, etc.
- Point-and-stare observing plan from super-geostationary orbit
- Transient alerts within <20 min
 - 12-month proprietary non-alert data
- NASA participation:
 - Rideshare launch to GTO
 - Science team membership – competed slots (via ROSES) on Working Groups with full data access during proprietary period
 - Enabling community-wide data analysis through availability in NASA archive & ADAP/XRP
 - Participation in alert definition & protocols



ULTRASAT Concept
Source: Israel Aerospace Industries (IAI)

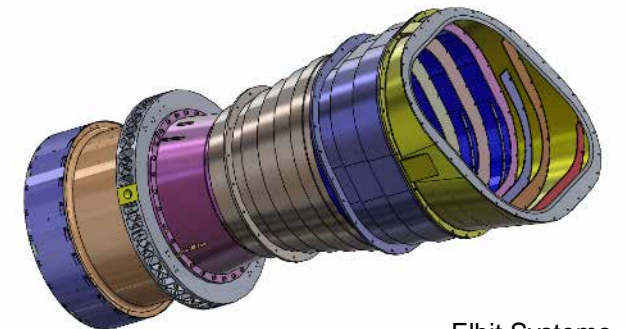

Elbit Systems

Nancy Grace Roman Space Telescope

Science Program

- Cosmology : Dark energy and the fate of the universe – wide field surveys to measure the expansion history and the growth of structure
- Exoplanet Demographics: The full distribution of planets around stars through a microlensing survey
- Astrophysics: Wide-field infrared surveys of the universe through General Observer and Archival Research programs

Technology development for the characterization of exoplanets through a Coronagraph Instrument Technology Demonstration

<https://roman.gsfc.nasa.gov/>

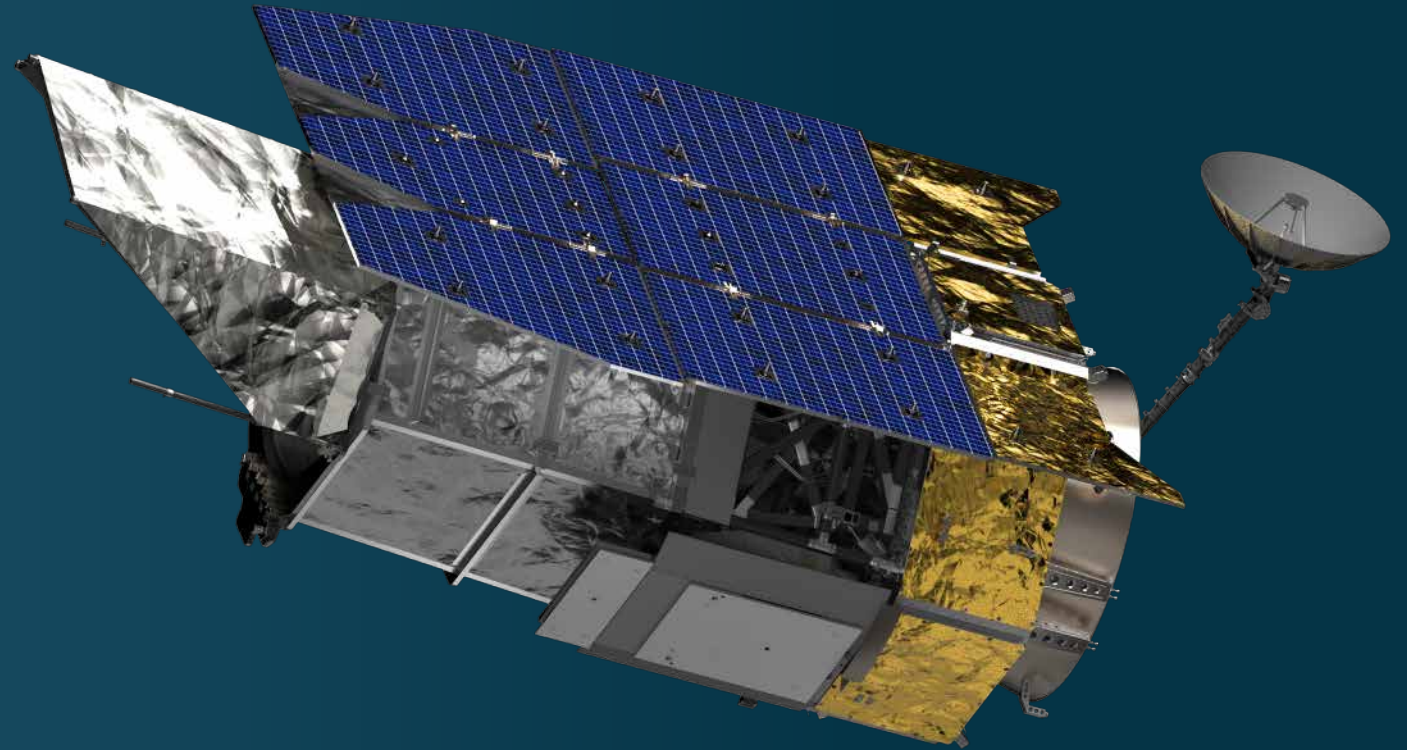

Roman field-of-view is 100× Hubble field-of-view

Roman is 100 to 1500 times faster than Hubble for large surveys at equivalent area and depth



Roman Space Telescope

Roman Science Interest Group (RSIG) formed to provide broad-based community input to the Roman project and NASA headquarters

- § Kickoff meeting held October 7

- § Documents in/out of RSIG posted on <https://roman.gsfc.nasa.gov/science/rsig.html>

Ground System Preliminary Design Review (last PDR) passed on July 24

Instrument Carrier Critical Design Review (first CDR) passed on September 17

During the FY21 CR NASA is continuing to make progress on Roman consistent with the budget profile planned at Phase C start

COVID-19 update:

- § On-site work taking place at GSFC and JPL with per-activity center permission

- § Work continues at contractors and international partners, consistent with local situations

- § Technical progress is good, despite unexpected challenges due to COVID-19

- § Impacts to schedule and cost: work delayed at NASA, JPL, international partners, contractors, and suppliers; unknown when will return to full efficiency

Roman Hardware Progress

Roman Space Telescope

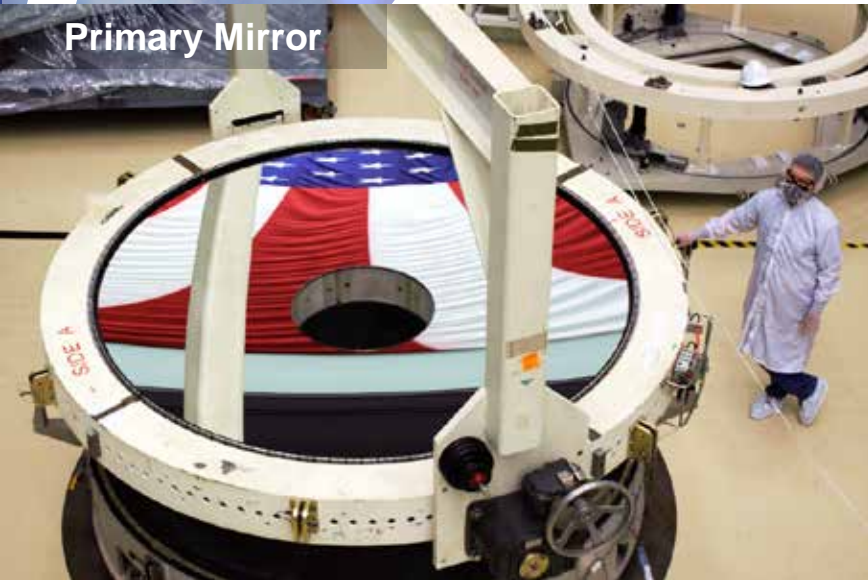

- Primary mirror, secondary mirror, and tertiary collimating assembly mirrors all coated and complete. Wide field tertiary being polished.
- Engineering Development unit for the Element Wheel and the mechanical model of the prism and grism are in testing to help finalize production specifications.
- Teledyne continues to deliver flight candidate detectors; 13 of 18 identified; continuing evaluation at GSFC

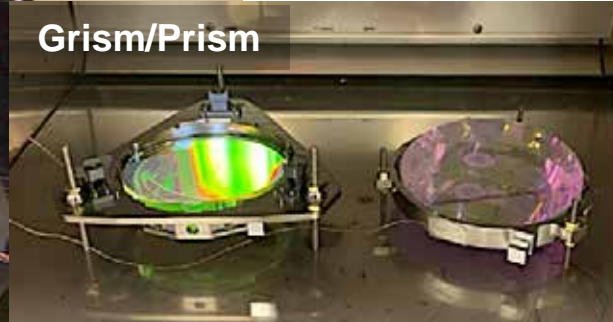
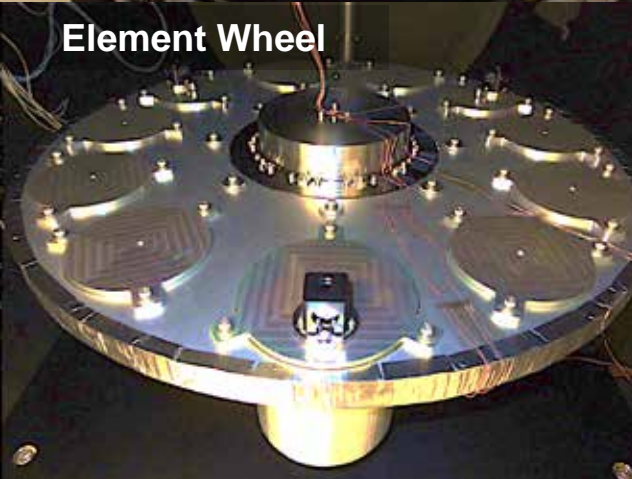

- Starting peer review and element review processes that lead to Mission CDR next summer.

Coronagraph Instrument Technology Demonstration



- JPL is making progress on schedule-critical Coronagraph work such as deformable mirrors.
- e2v is progressing on photon-counting EMCCD camera.



Roman is for the Community

All Roman observing time is available through open processes

- Major Legacy Surveys will be defined using a community-driven open process
- Key Projects – funded science investigations using these surveys – will be openly competed
- Roman observing time will be available for General Observer (GO) projects
- All data will be available to the community with no period of limited access

Roman operations will be based on community input

- NASA and STScI have convened community groups to provide input on balance among observing programs and on trades during development, integration, and test

Roman General Observers / Archival Researchers Program

- Use observing time for conducting wide-field infrared surveys of the universe
- Use data from Roman Legacy Surveys for compelling astrophysics investigations
- Calls for proposals to be issued before launch and subsequently

Roman Coronagraph Community Participation Program

- Ensure “as built” coronagraph is an effective demonstration
- Call for proposals at the appropriate time



NASA Astrophysics Decadal Survey Status



Astrophysics

Decadal Survey Missions

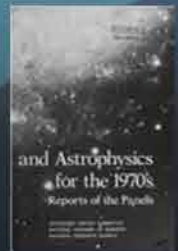

1972
Decadal Survey
Hubble

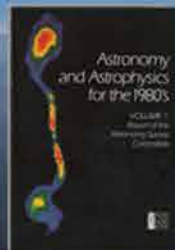

1982
Decadal Survey
Chandra

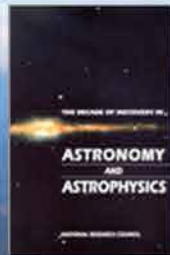

1991
Decadal Survey
Spitzer

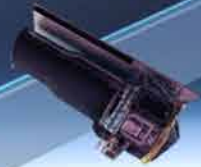

2001
Decadal Survey
Webb

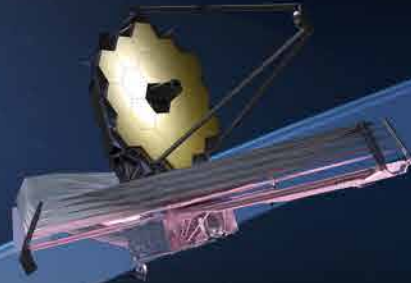

2010
Decadal Survey
Roman



2021
Decadal Survey



Strategy 1.1: Execute a balanced science program based on guidance from the National Academies, Administration priorities, and direction from Congress.

Astro2020 Decadal Survey Status



- Large Mission Concept Studies presented to Astro2020 in November 2019
- Last public meeting of the Steering Committee on August 25, 2020
 - Agencies presented updated programmatic and budget guidance
- Co-Chairs stated that publicly that report will be delivered in Spring 2021
- APD is planning ahead for implementing the Decadal Survey
 - Risk reduction technology development underway
 - Planning for recommendations in R&A, archives, etc. underway
 - Open process to develop options for Probe and flagship pre-formulation management underway
 - Holding a \$50-100M per year wedge in out year planning budget for new initiatives

- Formulation
- Implementation
- Primary Ops
- Extended Ops

+ SMEX/MO (2025),
MIDEX/MO (2028), etc.



Spitzer
8/25/2003
1/30/2020

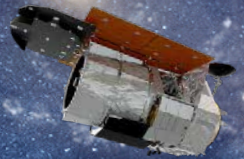

Roman
2025/2026



Euclid (ESA)
2022



SXG (RSA)
7/13/2019

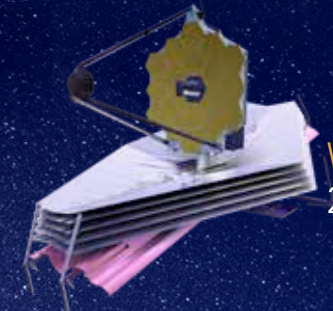

Webb
2021



Ariel (ESA)
2028



Chandra
7/23/1999

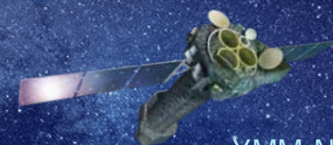

XMM-Newton (ESA)
12/10/1999

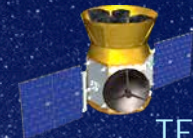

TESS
4/18/2018

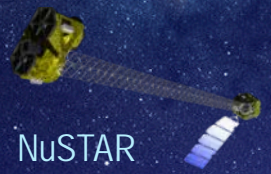

NuSTAR
6/13/2012



Fermi
6/11/2008

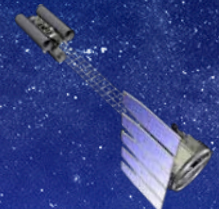

IXPE
2021



Swift
11/20/2004

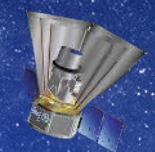

SPHEREx
2023

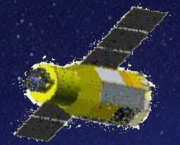

XRISM (JAXA)
2022

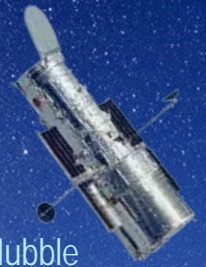

Hubble
4/24/1990



ISS-NICER
6/3/2017



GUSTO
2021

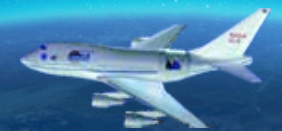

SOFIA
Full Ops 5/2014

+ Athena (early 2030s),
LISA (early 2030s)

Astrophysics Budget

	Actual 2019	Actual 2020	Request 2021	2022	Out-years		
					2023	2024	2025
Astrophysics	1,191.1	1,306.1	831.0	891.2	1,000.9	959.7	975.5
<u>Astrophysics Research</u>	<u>222.8</u>	<u>231.2</u>	<u>269.7</u>	<u>279.1</u>	<u>327.2</u>	<u>314.9</u>	<u>331.1</u>
Astrophysics Research and Analysis	83.4	86.6	90.2	92.2	94.2	94.2	94.2
Balloon Project	40.2	44.8	44.8	45.8	45.7	46.3	46.3
Science Activation	45.0	45.6	45.6	45.6	45.6	45.6	45.6
Astrophysics Directed R&T	4.5	-	25.7	29.4	23.3	9.0	25.5
Other Missions and Data Analysis	49.7	54.3	63.4	66.1	118.4	119.8	119.5
<u>Cosmic Origins</u>	<u>222.8</u>	<u>202.7</u>	<u>124.0</u>	<u>123.2</u>	<u>120.0</u>	<u>122.4</u>	<u>122.4</u>
Hubble Space Telescope Operations	98.3	90.8	88.3	98.3	98.3	98.3	98.3
SOFIA	85.2	85.2	12.0	-	-	-	-
Other Missions and Data Analysis	39.3	26.7	23.7	24.9	21.7	24.1	24.1
<u>Physics of the Cosmos</u>	<u>151.2</u>	<u>132.8</u>	<u>143.9</u>	<u>160.8</u>	<u>155.3</u>	<u>169.8</u>	<u>154.1</u>
Euclid	17.2	7.1	11.0	8.9	9.9	10.3	9.5
Fermi Gamma-ray Space Telescope	16.5	13.1	13.8	13.9	-	-	-
Chandra X-Ray Observatory	61.7	60.2	62.3	62.8	62.8	62.8	62.8
XMM	4.5	3.5	3.5	3.5	-	-	-

Astrophysics Budget

	Actual 2019	Actual 2020	Request 2021	2022	Out-years		
					2023	2024	2025
<u>Exoplanet Exploration</u>	<u>367.9</u>	<u>554.2</u>	<u>47.2</u>	<u>50.4</u>	<u>47.6</u>	<u>51.6</u>	<u>52.2</u>
WFIRST	312.2	510.7	-	-	-	-	-
Keck Operations	6.5	6.6	6.9	7.0	7.2	7.4	7.4
Kepler	8.9	1.3	-	-	-	-	-
<u>Astrophysics Explorer</u>	<u>226.5</u>	<u>185.3</u>	<u>246.2</u>	<u>277.7</u>	<u>350.8</u>	<u>301.0</u>	<u>315.6</u>
X-Ray Imaging and Spectroscopy Mission	23.2	24.2	25.1	36.3	17.7	15.9	14.4
Spectro-Photometer for the History of th	22.2	58.7	90.8	109.1	87.7	28.4	13.0
Contribution to ARIEL Spectroscopy of Ex	-	1.0	11.9	10.2	10.0	6.4	1.0
Astrophysics Explorer Future Missions	2.3	7.6	10.6	58.0	219.2	241.5	278.1
Astrophysics Explorer Program Management	4.9	5.0	20.7	18.0	10.7	8.3	9.1
Neutron Star Interior Composition Explor	3.8	4.8	4.8	4.4	-	-	-
Transiting Exoplanet Survey Satellite	7.7	7.4	14.7	14.1	-	-	-
Imaging X-Ray Polarimetry Explorer	57.0	59.5	45.3	7.4	4.5	0.5	-
Galactic/Extragalactic ULDB Spectroscopi	19.9	3.4	7.8	5.8	1.0	-	-
Neil Gehrels Swift Observatory	7.0	6.0	5.8	5.8	-	-	-
Nuclear Spectroscopic Telescope Array	8.5	7.8	8.6	8.6	-	-	-
<u>James Webb Space Telescope</u>	<u>305.1</u>	<u>423.0</u>	<u>414.7</u>	<u>175.4</u>	<u>172.0</u>	<u>172.0</u>	<u>172.0</u>
<u>Astrophysics + Webb Total</u>	<u>1,496.2</u>	<u>1,729.1</u>	<u>1,245.7</u>	<u>1,066.6</u>	<u>1,172.9</u>	<u>1,131.7</u>	<u>1,147.5</u>

Associate Administrator (AA)

Thomas Zurbuchen

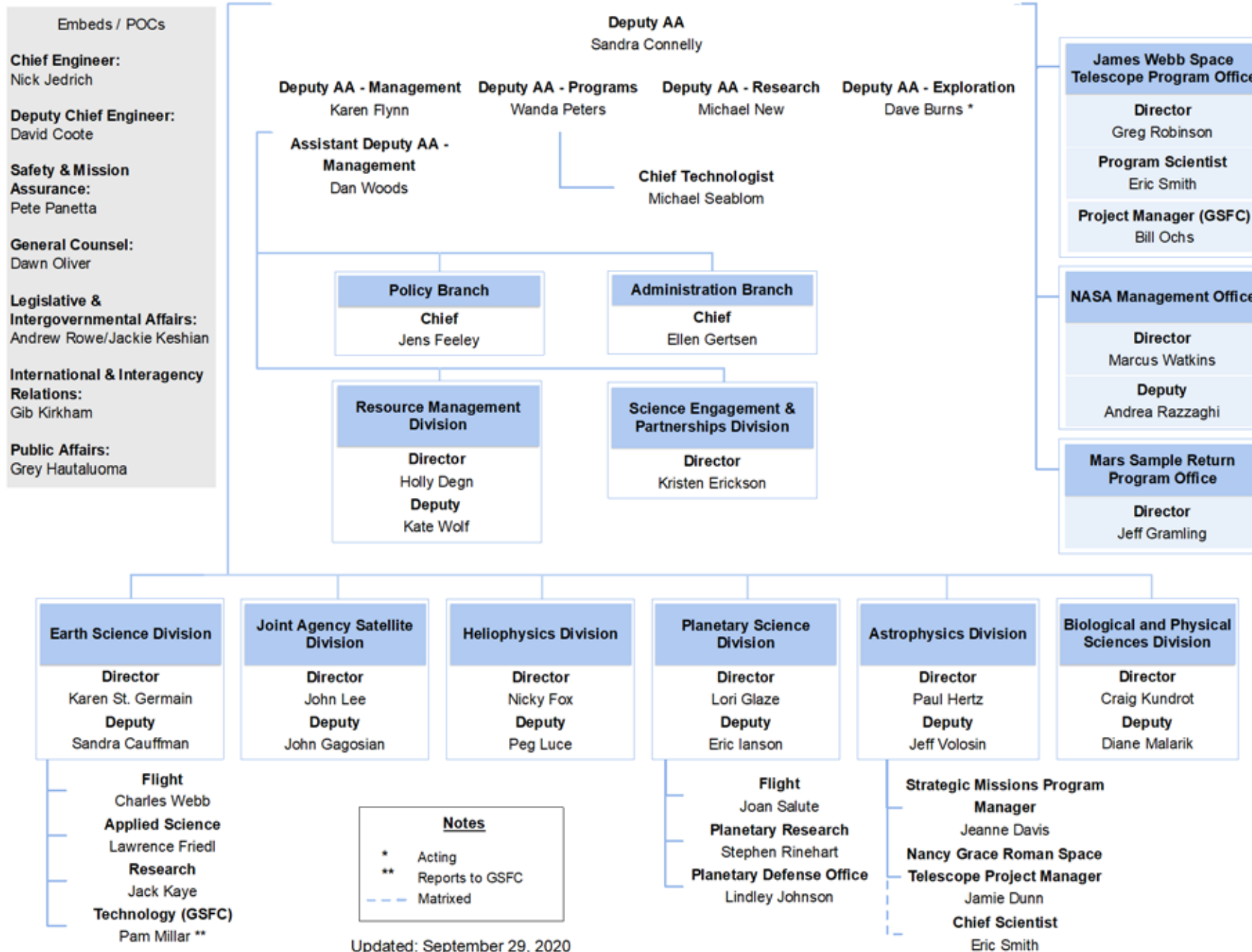

Nancy Grace Roman Space Telescope



SCIENCE
HIGHLIGHT



May 20, 2020 – NASA has named its Wide Field Infrared Survey Telescope (WFIRST), in honor of Nancy Grace Roman, NASA's first chief astronomer, who paved the way for space telescopes focused on the broader universe.

Nancy Grace Roman Space Telescope

Driving Science Objectives:

Characterize the history of cosmic acceleration and structure growth

Understand how planetary systems form and evolve and determine the prevalence of planets in the colder outer regions

Provide a peer-reviewed General Observer & Archival Research program

Develop and fly a technology demonstration of advanced starlight suppression technology, which could be used for direct imaging and spectroscopy of planets and debris disks.

Capabilities:

Wide-field imaging 100-1,500 times faster than Hubble

Near-infrared optimized; greater IR sensitivity than any prior mission \hat{a} best wide field imaging ever achieved

Camera 100x wider field of view than Hubble; angular resolution of $\approx 0.1''$ rivals Hubble

Starlight suppression up to 100x better than previously achieved on ground, 1000x better than achieved in space

- **Mission Risk Class:** Class A tailored
- **Mission Duration:** 5 years science; designed for 10 around Sun-Earth L2
- **Orbit:** around Sun-Earth L2
- **Ground Stations:** NEN, DSN, ESA (Australia), JAXA
- **Space Network:** S-band for launch
- **Ground System:** MOC/Science Ops Ctr/Science Spprt Ctr
- **Launch Vehicle:** TBD
- **Launch Site:** Eastern Range
- **Launch Png Date:** October 2025 (pre-COVID)
- **Telescope diam.:** 2.4m
- **Observatory size:** 12.4m
- **Dry Mass:** 7801kg
- **Data Volume:** 1.5 TB/day; 20PB after 5 years

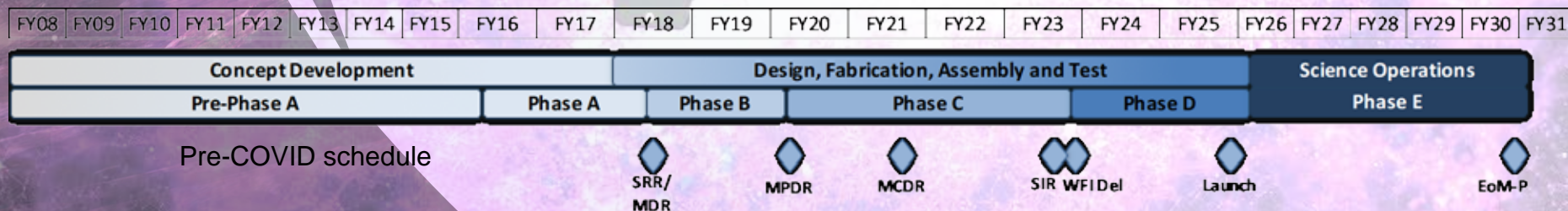

Astrophysics Explorers Program

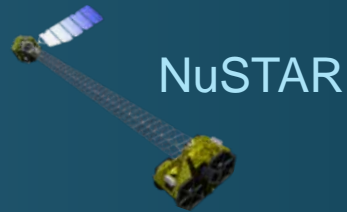

MIDEX 2021 Community
Announcement released
September 29, 2020

4 AOs per decade

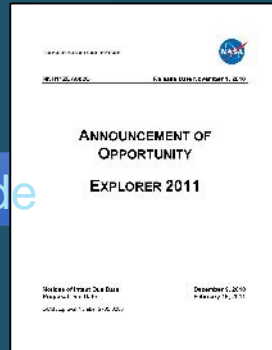

MIDEX
2011



SMEX
2014

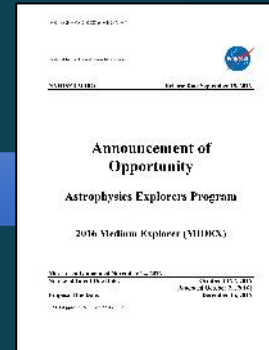

MIDEX
2016



SMEX
2019

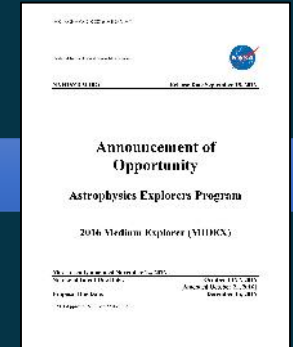

MIDEX
2021

Small and
Mid-Size
Missions



Missions of
Opportunity



Astrophysics R&A Peer Reviews

2021

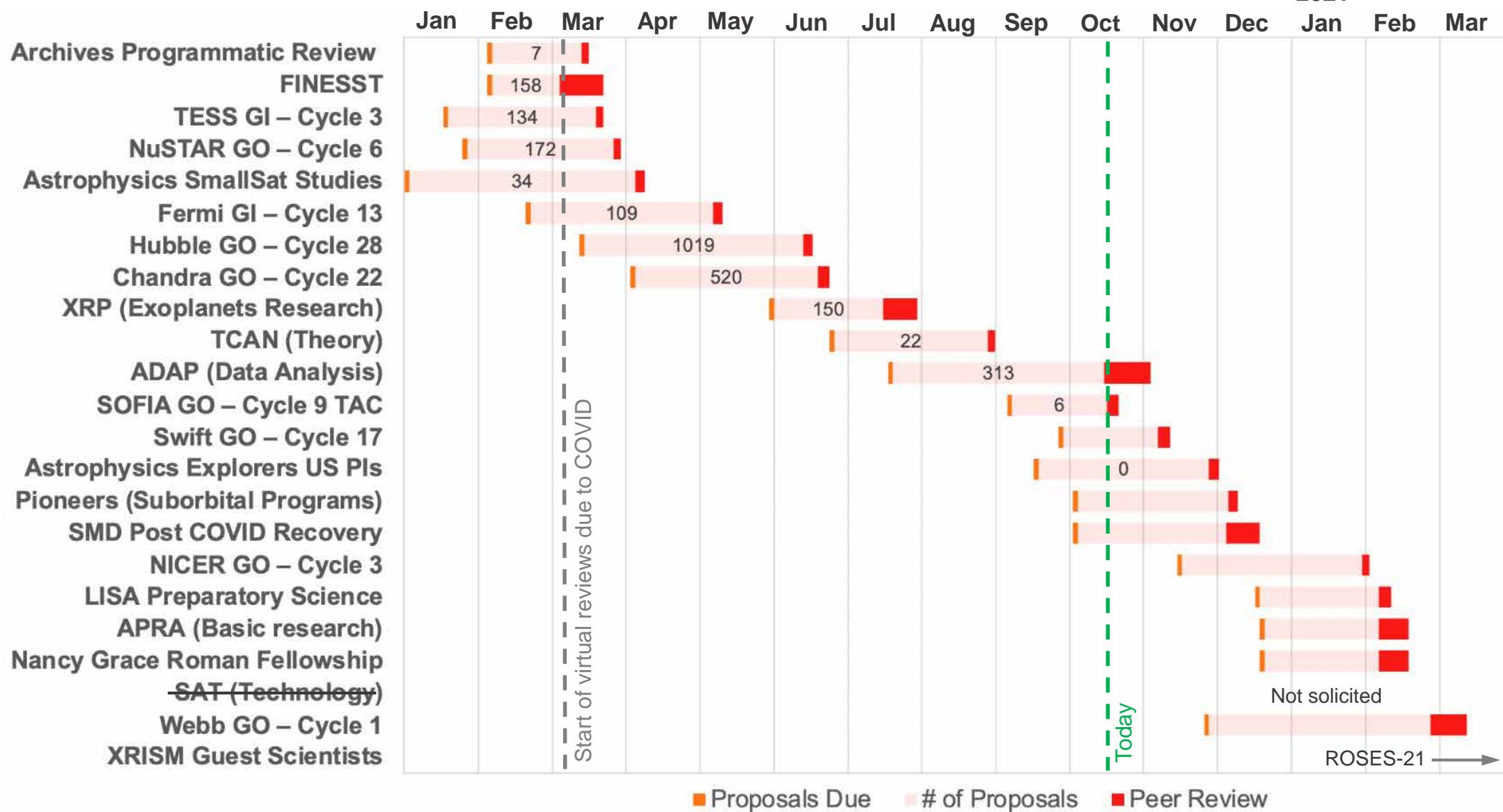



Hubble Helps Uncover the Mystery of the Dimming of Betelgeuse

Released: August 13, 2020

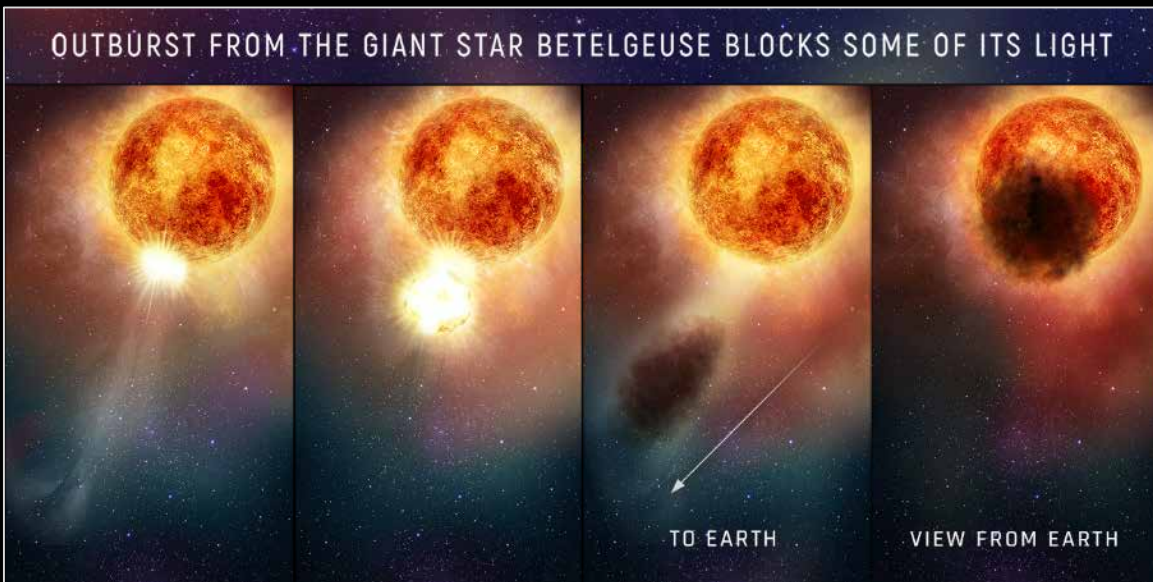

Image Credit: NASA, ESA, and E. Wheatley (STScI)

Caption: Illustration of outburst from Betelgeuse

A. Dupree et al., <https://doi.org/10.3847/1538-4357/aba516>

<https://www.nasa.gov/feature/goddard/2020/hubble-finds-that-betelgeuses-mysterious-dimming-is-due-to-a-traumatic-outburst>

- The aging, bright-red supergiant star Betelgeuse has captivated sky watchers since antiquity. It is one of the brightest stars in the night sky and appears even more luminous because it is so close to Earth, only 725 light-years away.
- The star periodically changes in brightness as the star expands and contracts, brightening and dimming, on a 420-day cycle.
- In October 2019, the star dimmed dramatically and continued to become even fainter. By mid-February 2020, the star had lost more than two-thirds of its brilliance.
- This sudden dimming mystified astronomers, who scrambled to develop theories for the abrupt change.
- Ultraviolet observations by the Hubble Space Telescope suggest that the unexpected dimming was probably caused by an immense amount of superhot material ejected into space.
- The material cooled and formed a dust cloud that blocked the starlight coming from about a quarter of Betelgeuse's surface.
- Hubble captured signs of dense, heated material moving through the star's atmosphere in September, October, and November 2019. In December, several ground-based telescopes observed the star decreasing in brightness in its southern hemisphere.
- The giant star is destined to end its life in a supernova blast. Some astronomers think the sudden dimming may be a pre-supernova event.
- Betelgeuse resides in Orion, one of the most recognizable constellations in the sky.

Exploring Galaxy TXS 0128

Released: August 25, 2020

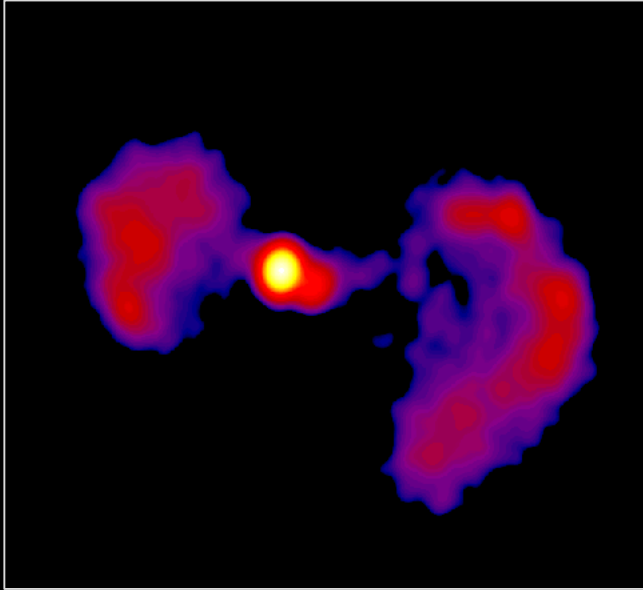

Image Credit: NRAO

Caption: This image shows TXS 0128 at 15.4 gigahertz as observed by the Very Long Baseline Array (VLBA), a globe-spanning network of radio antennas. The colors correspond to the radio signal's intensity, from low (purple) to high (yellow).

M.L. Lister et al., <https://iopscience.iop.org/article/10.3847/1538-4357/aba18d>

<https://www.nasa.gov/feature/goddard/2020/nasa-missions-explore-a-tie-fighter-active-galaxy>



SCIENCE
HIGHLIGHT

- The galaxy TXS 0128+554 (TXS 0128 for short) was recently studied by the Fermi Gamma-ray Space Telescope, the Chandra X-ray Observatory, and the Very Long Baseline Array (a globe-spanning network of radio antennas).
- TXS 0128 lies 500 million light-years away in the constellation Cassiopeia. It is anchored by a supermassive black hole around one billion times the Sun's mass.
- TXS 0128 is classified as an active galaxy, which means all its stars together can not account for the amount of light it emits. An active galaxy's extra energy includes excess radio, X-ray, and gamma-ray light. Scientists think this emission arises from regions near its central black hole, where a swirling disk of gas and dust accumulates and heats up because of gravitational and frictional forces.
- Around one-tenth of active galaxies produce a pair of jets, beams of high-energy particles traveling at nearly the speed of light in opposite directions. Astrophysicists think these jets produce gamma rays.
- In some cases, collisions with tenuous intergalactic gas eventually slow and halt the outward motion of jet particles, and the material starts to flow back toward the galaxy's center. This results in broad regions, or lobes, filled with fast-moving particles spiraling around magnetic fields. The particle interactions create bright radio emission.
- TXS 0128's jets appear to have started around 90 years ago, as observed from Earth, and then stopped about 50 years later, leaving behind the unconnected lobes. Then, roughly a decade ago, the jets turned on again, producing the emission seen closer to the core. What caused the sudden onset of these active periods remains unclear.



Measuring the Masses of Magnetic White Dwarfs

Released: September 22, 2020

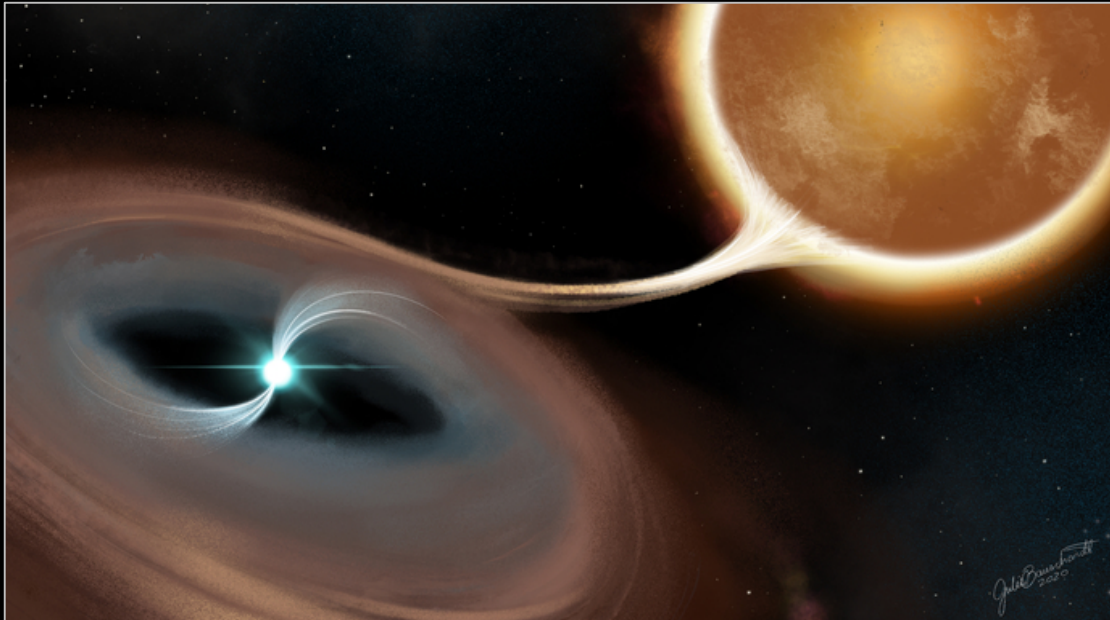

Credit: Julie Bauschardt

Caption: Artist's impression of a magnetic cataclysmic variable: Material from the companion star (right) flows towards the hot white dwarf (left) and forms an accretion disk. The magnetic field of the white dwarf is strong enough to disrupt the innermost regions of the disk, forcing the material to flow along the magnetic field lines on to the poles of the white dwarf.

A.W. Shaw et al., <https://doi.org/10.1093/mnras/staa2592>

<https://www.nustar.caltech.edu/news/118>

- White dwarfs are the end-stage of stars like our own Sun – dense, hot cores of dead stars that are comparable to the size of the Earth. Often, white dwarfs are found in binary systems accreting matter from another Sun-like star, forming a disk of hot material around the white dwarf and emitting light across the electromagnetic spectrum.
- Astronomers have used NASA's Nuclear Spectroscopic Telescope Array (NuSTAR) to conduct a deep survey of a subset of these accreting systems called magnetic cataclysmic variables (CVs), where the central white dwarf has a magnetic field more than one million times stronger than that of the Earth's.
- In magnetic CVs, the material from the companion star flows along the magnetic field lines and, when it reaches the surface of the white dwarf, forms a shock that heats up to millions of degrees. The temperature of this shock is directly related to the gravity of the white dwarf and therefore its mass, and can be measured by studying the X-rays that the shock produces, which are observed by NuSTAR.
- The NuSTAR survey found that the white dwarfs in magnetic CVs typically have a mass $\frac{3}{4}$ that of the Sun. This is contrary to non-accreting white dwarfs, which have an average mass approximately $\frac{1}{2}$ that of the Sun.
- Previous studies of a different population of regular, non-magnetic CVs found a similar answer – $\frac{3}{4}$ of the mass of the Sun – leading to the conclusion that all accreting white dwarfs, whether non-magnetic or not, are more massive than their non-accreting counterparts.
- Another theory is that the lower-mass accreting white dwarfs could instead be hidden from view because the accretion phase is unstable and they “disappear” as X-ray sources.