

Best Practices for Hosted Payload Interface Design Guidelines Document		
Document No: BPHPID0001	Effective 3/23/2017	Version: DRAFT
		Page 1 of 60

Best Practices for Hosted Payload Interface Design Guidelines

March 23, 2017

A Collaborative Project
by
NASA ESSP Program Office
SMC Hosted Payload Office
The Aerospace Corporation

Best Practices for Hosted Payload Interface Design Guidelines Document		
Document No: BPHPID0001	Effective 3/23/2017	Version: DRAFT
		Page 2 of 60

Submitted By:

Cary D. Pao
Senior Project Leader
The Aerospace Corporation

Date

Daniel E. Torres, Captain, USAF
Project Manager, Hosted Payload Office

Date

C. Randy Regan
CII Project Manager
NASA ESSP Chief Engineer

Date

Approved By:

Doug Holker
Associate Principal Director
The Aerospace Corporation

Date

D. Jason Cothorn, Colonel, USAF
Chief, Space Demonstrations Director

Date

Gregory Stover
NASA ESSP PO Program Director

Date

Best Practices for Hosted Payload Interface Design Guidelines Document		
Document No: BPHPID0001	Effective 3/23/2017	Version: DRAFT
		Page 4 of 60

Table of Contents

1.0	OVERVIEW	6
1.1	Introduction	6
2.0	Best Practices for leo	7
2.1	Data Interface Reference Material / Best Practices	7
2.1.1	CCSDS Data Transmission.....	7
2.1.2	Flight Software Update	7
2.1.3	Flight Software Update (Partial).....	7
2.1.4	Use of Preexisting Communication Infrastructure	7
2.2	Electrical Power Interface Reference Material / Best Practices	7
2.2.1	Electrical Interface Definitions	8
2.2.2	Survival Heaters.....	8
2.2.3	Voltage and Current Transients	9
2.2.4	Overcurrent Protection.....	11
2.2.5	Connectors	12
2.3	Mechanical Interface Reference Material / Best Practices	17
2.3.1	Mass Centering	17
2.3.2	Documentation of Mechanical Properties.....	17
2.3.3	Dynamic Properties.....	18
2.3.4	Instrument Mounting	19
2.3.5	Instrument Alignment	20
2.3.6	Integration and Test	21
2.4	Thermal Interface Reference Material / Best Practices.....	23
2.4.1	Heat Management Techniques.....	23
2.4.2	Survival Heaters.....	24
2.4.3	Thermal Performance and Monitoring.....	25
2.5	Environmental Reference Material / Best Practices.....	26
2.5.1	Radiation-Induced SEE.....	26
2.6	Software Engineering Reference Material / Best Practices	26
2.7	Contamination Reference Material / Best Practices.....	26
2.7.1	Assumptions.....	26
2.7.2	Instrument Generated Contamination	27
2.7.3	Accommodation of Externally Generated Contamination.....	29
2.7.4	Instrument Purge Requirements.....	29
2.8	Model Guidelines and Submittal Details	31
2.8.1	Finite Element Model Submittal.....	31
2.8.2	Thermal Math Model	31
2.8.3	Thermal Analytical Models	32
2.8.4	Mechanical CAD Model	32
2.8.5	Mass Model.....	33
3.0	BEST PRACTICES FOR GEO.....	34

3.1	Data Interface Reference Material / Best Practices -----	34
3.1.1	<i>CCSDS Data Transmission</i>	34
3.1.2	<i>Flight Software Update</i>	34
3.1.3	<i>Flight Software Update (Partial)</i>	34
3.1.4	Use of Preexisting Communication Infrastructure	34
3.2	Electrical Power Interface Reference Material / Best Practices -----	34
3.2.1	Electrical Interface Definitions	35
3.2.2	Survival Heaters.....	35
3.2.3	Voltage and Current Transients	36
3.2.4	Overcurrent Protection.....	38
3.2.5	Connectors	40
3.3	Mechanical Interface Reference Material / Best Practices -----	44
3.3.1	Mass Centering	44
3.3.2	Documentation of Mechanical Properties.....	44
3.3.3	Dynamic Properties.....	45
3.3.4	Instrument Mounting	46
3.3.5	Instrument Alignment	47
3.3.6	Integration and Test	48
3.4	Thermal Interface Reference Material / Best Practices -----	51
3.4.1	Heat Management Techniques.....	51
3.4.2	Survival Heaters.....	52
3.4.3	Thermal Performance and Monitoring.....	52
3.5	Environmental Reference Material / Best Practices -----	53
3.5.1	Radiation-Induced SEE.....	53
3.6	Software Engineering Reference Material / Best Practices -----	54
3.7	Contamination Reference Material / Best Practices -----	54
3.7.1	Assumptions.....	54
3.7.2	Instrument Generated Contamination	55
3.7.3	Accommodation of Externally Generated Contamination.....	57
3.7.4	Instrument Purge Requirements.....	57
3.8	Model Guidelines and Submittal Details -----	59
3.8.1	Finite Element Model Submittal	59
3.8.2	Thermal Math Model	59
3.8.3	Thermal Analytical Models	60
3.8.4	Mechanical CAD Model	60
3.8.5	Mass Model.....	60

Best Practices for Hosted Payload Interface Design Guidelines Document		
Document No: BPHPID0001	Effective 3/23/2017	Version: DRAFT
		Page 6 of 60

1.0 OVERVIEW

1.1 Introduction

This Best Practices for Hosted Payload Interface Design Guidelines document is the result of a collaborative project between the NASA Common Instrument Interface (CII) team, the Earth System Science Pathfinder Program Office, the USAF Space and Missile Center's Hosted Payload Office, and The Aerospace Corporation. This Hosted Payload Interface Design (HPID) Guidelines document provides a prospective Instrument Developer with technical recommendations to assist them in designing an Instrument or Payload that may be flown as a hosted payload on commercial satellites flown in Low Earth Orbit (LEO), or Geostationary Earth Orbit (GEO). This document supersedes the Common Instrument Interface Project's Hosted Payload Guidelines Document previously published by the NASA Earth System Science Pathfinder (ESSP) Program Office

Best Practices for Hosted Payload Interface Design Guidelines Document		
Document No: BPHPID0001	Effective 3/23/2017	Version: DRAFT
		Page 7 of 60

2.0 BEST PRACTICES FOR LEO

2.1 Data Interface Reference Material / Best Practices

2.1.1 CCSDS Data Transmission

The Instrument should transmit and receive all packet data using Consultative Committee for Space Data Systems (CCSDS) primary and secondary headers for packet sequencing and control.

Rationale: The use of CCSDS packets for data communication is common practice across aerospace flight and ground data systems.

2.1.2 Flight Software Update

Instrument control flight software should be updatable on orbit through ground command.

Rationale: On-orbit flight software updates are a best practice that facilitates improvements and/or workarounds deemed necessary through operational experience.

2.1.3 Flight Software Update (Partial)

Individual memory addresses of instrument control software should be updatable on orbit through ground command.

Rationale: On-orbit flight software updates are a best practice that facilitates improvements and/or workarounds deemed necessary through operational experience.

2.1.4 Use of Preexisting Communication Infrastructure

As a best practice, Instrument Developers should consider utilizing the communication infrastructure provided by the Host Spacecraft and Satellite Operator for all of the Instrument's space-to-ground communications needs.

Rationale: The size, mass, and power made available to the Instrument may not simultaneously accommodate a scientific Instrument as well as communications terminals, antennas, and other equipment. Additionally, the time required for the Instrument Developer to apply for and secure a National Telecommunications and Information Administration (NTIA) Spectrum Planning Subcommittee (SPS) Stage 4 (operational) Approval to transmit on a particular radio frequency band may exceed the schedule available, given the constraints as a hosted payload. A Satellite Operator will have already initiated the spectrum approval process that would cover any data the Instrument transmits through the Host Spacecraft. NPR 2570.1B, *NASA Radio Frequency (RF) Spectrum Management Manual*, details the spectrum approval process for NASA missions.

2.2 Electrical Power Interface Reference Material / Best Practices

Note: This section assumes that the Host Spacecraft will provide access to its Electrical Power System using the interface defined in Section **Error! Reference source not found.**

Best Practices for Hosted Payload Interface Design Guidelines Document		
Document No: BPHPID0001	Effective 3/23/2017	Version: DRAFT
		Page 8 of 60

2.2.1 Electrical Interface Definitions

2.2.1.1 *Power Bus Current Rate of Change*

For power bus loads with current change greater than 2 A, the rate of change of current should not exceed 500 mA/μs.

Rationale: This describes the maximum nominal rate of change for instrument electrical current to bound nominal and anomalous behavior.

2.2.1.2 *Power Bus Isolation*

All Instrument power buses (both operational and survival) should be electrically isolated from each other and from the chassis.

Rationale: Circuit protection and independence.

2.2.1.3 *Power Bus Returns*

All Instrument power buses (both operational and survival heater) should have independent power returns.

Rationale: Circuit protection and independence.

2.2.2 Survival Heaters

2.2.2.1 *Survival Heater Power Bus Circuit Failure*

The Instrument survival heater circuit should prevent a stuck-on condition of the survival heaters due to internal failures.

Rationale: A stuck-on survival heater could lead to excessive power draw and/or over-temperature events in the Instrument or Host Spacecraft. This is normally accomplished by using series-redundant thermostats in each survival heater circuit.

2.2.2.2 *Survival Heater Power Bus Heater Type*

The Instrument should use only resistive heaters (and associated thermal control devices) to maintain the Instrument at survival temperature when the main power bus is disconnected from the Instrument.

Rationale: This preserves the survival heater power bus for exclusive use of resistive survival heaters, whose function is to maintain the Instrument at a minimum turn-on temperature when the Instrument Power Buses are not energized.

2.2.2.3 *Survival Heater Power Bus Design*

The system design should allow enabling of both primary and redundant survival heater circuits without violating any thermal or power requirement.

Best Practices for Hosted Payload Interface Design Guidelines Document		
Document No: BPHPID0001	Effective 3/23/2017	Version: DRAFT
		Page 9 of 60

Rationale: This precludes excessive power draw and/or over-temperature events in the Instrument or Host Spacecraft. This is normally accomplished via the application of thermostats with different set points in each redundant survival heater circuit.

2.2.3 Voltage and Current Transients

2.2.3.1 *Low Voltage Detection*

A voltage excursion that causes the spacecraft Primary Power Bus to drop below 22 VDC in excess of four seconds constitutes an under-voltage condition. In the event of an under-voltage condition, the Host Spacecraft will shed various loads without delay, including the Instrument. A ground command should be required to re-power the loads, including the Instrument

Rationale: Bounds nominal and anomalous design conditions. Describes “typical” spacecraft CONOPS to the noted anomaly for application to design practice.

2.2.3.2 *Bus Undervoltage and Overvoltage Transients*

Derating factors should take into account the stresses that components are subjected to during periods of undervoltage or overvoltage, including conditions which arise during ground testing, while the bus voltage is slowly increased to its nominal value.

Rationale: This design feature describes a “standard” design practice.

2.2.3.3 *Bus Undervoltage and Overvoltage Transients Response*

The Instrument should not generate a spurious response that can cause equipment damage or otherwise be detrimental to the spacecraft operation during bus voltage variation, either up or down, at ramp rates below the limits specified in the sections below, and over the full range from zero to maximum bus voltage.

Rationale: The Instrument must tolerate appropriate electrical transients without affecting the Host Spacecraft.

2.2.3.4 *Abnormal Transients Undervoltage*

An abnormal undervoltage transient event is defined as a transient decrease in voltage on the Power Bus to no less than +10 VDC, maintaining the decreased voltage for no more than 10 ms, and returning to its previous voltage in less than 200 ms.

Rationale: The Instrument must tolerate the abnormal voltage transients, which can be expected to occur throughout its mission lifetime.

2.2.3.5 *Abnormal Transients Tolerance*

The Instrument should ensure that overstress does not occur to the unit during a transient undervoltage event.

Best Practices for Hosted Payload Interface Design Guidelines Document		
Document No: BPHPID0001	Effective 3/23/2017	Version: DRAFT
		Page 10 of 60

Rationale: The Instrument must tolerate the abnormal voltage transients, which can be expected to occur throughout its mission lifetime.

2.2.3.6 *Abnormal Transients Recovery*

Units which shut-off during an undervoltage should be capable of returning to a nominal power-up state at the end of the transient.

Rationale: The Instrument needs to tolerate the abnormal voltage transients, which can be expected to occur throughout its mission lifetime.

2.2.3.7 *Abnormal Transients Overvoltage*

An overvoltage transient event is defined as an increase in voltage on the Power Bus to no greater than +40 VDC, maintaining the increased voltage for no more than 10 ms, and returning to its previous voltage in less than 200 ms.

Rationale: A necessary definition of an Abnormal Transient Overvoltage

2.2.3.8 *Instrument Initial In-rush Current*

After application of +28 VDC power at t_0 , the initial inrush (charging) current due to distributed capacitance, EMI filters, etc., should be completed in 10 μ s with its peak no greater than 10 A.

Rationale: Bounds nominal and anomalous behavior.

2.2.3.9 *Instrument Initial In-rush Current Rate of Change*

The rate of change of inrush current after the initial application of +28V power should not exceed 20 mA/ μ s.

Rationale: Bounds nominal and anomalous behavior.

2.2.3.10 *Instrument In-rush Current after 10 μ s*

After 10 μ s, the transient current peak should not exceed three times the maximum steady state current.

Rationale: Bounds nominal and anomalous behavior.

2.2.3.11 *Instrument Steady State Operation*

Steady state operation should be attained within 50 ms from turn-on or transition to OPERATION mode, except for motors.

Rationale: Bounds nominal and anomalous behavior with a maximum transient duration of 50 ms.

Best Practices for Hosted Payload Interface Design Guidelines Document		
Document No: BPHPID0001	Effective 3/23/2017	Version: DRAFT
		Page 11 of 60

2.2.3.12 *Instrument Turn-off Peak Voltage Transients*

The peak voltage of transients generated on the Instrument side of the power relay caused by inductive effects of the load should fall within the -2 VDC to +40 VDC range.

Rationale: Bounds nominal behavior.

2.2.3.13 *Instrument Turn-off Transient Suppression*

The Instruments should use suppression devices, such as diodes, across all filter inductors, relay coils, or other energy sources that could induce transients on the power lines during turn-off.

Rationale: Describes design “standard practice.”

2.2.3.14 *Reflected Ripple Current – Mode Changes*

The load current ripple due to motor rotation speed mode changes should not exceed 2 times the steady state current during the period of the motor spin-up or spin-down.

Rationale: Bounds nominal behavior.

2.2.3.15 *Instrument Operational Transients Current Limit*

Operational transients that occur after initial turn-on should not exceed 125% of the peak operational current drawn during normal operation.

Rationale: Bounds nominal behavior.

2.2.3.16 *Instrument Reflected Ripple Current*

The peak-to-peak load current ripple generated by the Instrument should not exceed 25% of the average current on any Power Feed bus.

Rationale: Bounds nominal behavior.

2.2.4 Overcurrent Protection

2.2.4.1 *Overcurrent Protection Definition*

The analysis defining the overcurrent protection device specification(s) should consider turn-on, operational, and turn-off transients.

Rationale: Describes conditions necessary for inclusion in the “standard” design practice.

2.2.4.2 *Overcurrent Protection – Harness Compatibility*

Harness wire sizes should be consistent with overcurrent protection device sizes and derating factors.

Rationale: Describes a “standard” design practice.

Best Practices for Hosted Payload Interface Design Guidelines Document		
Document No: BPHPID0001	Effective 3/23/2017	Version: DRAFT
		Page 12 of 60

2.2.4.3 *Overcurrent Protection Device Size Documentation*

The EICD will document the type, size, and characteristics of the overcurrent protection devices.

Rationale: Describes “standard practice” EICD elements.

2.2.4.4 *Instrument Overcurrent Protection*

All Instrument overcurrent protection devices should be accessible at the Host Spacecraft integration level with minimal disassembly of the Instrument.

Rationale: Accessible overcurrent protection devices allow Systems Integrator technicians to more easily restore power to the Instrument in the event of an externally-induced overcurrent. This provides access to the overcurrent protection devices in order to both restore the integrity of the protected power circuit and to preclude the need for additional testing precipitated by Instrument disassembly.

2.2.4.5 *Instrument Fault Propagation Protection*

The Instrument and Host Spacecraft should not propagate a single fault occurring on either the “A” or “B” power interface circuit, on either side of the interface, to the redundant interface or Instrument.

Rationale: This preserves redundancy by keeping faulty power circuits from impacting alternate power sources.

2.2.4.6 *Testing of Instrument High-Voltage Power Supplies in Ambient Conditions*

Instrument high-voltage power supplies should operate nominally in ambient atmospheric conditions.

Rationale: This allows simplified verification of the high-voltage power supplies.

If the high-voltage power supplies cannot operate nominally in ambient conditions, then the Instrument design should enable a technician to manually disable the high-voltage power supplies.

Rationale: This allows verification of the Instrument by bypassing the HV power supplies that do not function in ambient conditions.

2.2.4.7 *Instrument High-Voltage Current Limiting*

The output of the high-voltage supply of each Instrument should be current limited to prevent the supply discharge from damaging the Host Spacecraft and other Instruments.

Rationale: This prevents the power supply from damaging the Host Spacecraft or other payloads.

2.2.5 Connectors

The following best practices apply to the selection and use of all interface connectors.

Best Practices for Hosted Payload Interface Design Guidelines Document		
Document No: BPHPID0001	Effective 3/23/2017	Version: DRAFT
		Page 13 of 60

2.2.5.1 *Instrument Electrical Power System Connector and Harnessing*

The Instrument electrical power system harnessing and connectors should conform to GSFC-733-HARN, IPC J-STD-001ES and NASA-STD-8739.4.

Rationale: Describes the appropriate design practices for all Instrument electrical power connections and harnessing.

2.2.5.2 *Connector Savers*

Throughout all development, integration, and test phases, connector savers should be used to preserve the mating life of component flight connectors.

Rationale: This practice serves to preserve the number of mate/de-mate cycles any particular flight connector experiences. Mate/de-mate cycles are a connector life-limiting operation. This practice also protects flight connects form damage during required connector mate/de-mate operations.

2.2.5.3 *Connector Separation*

The Instrument should physically separate the electric interfaces for each of the following functions:

- 1) +28 VDC bus power and return
- Telemetry and command signals with returns
- Deployment actuation power and return (where applicable)

Rationale: A “standard” design practice to preclude mismating and to simplify test and anomaly resolution.

2.2.5.4 *Command and Telemetry Returns*

Telemetry return and relay driver return pins should reside on the same connector(s) as the command and telemetry signals.

Rationale: A “standard” design practice to simplify testing and anomaly resolution.

2.2.5.5 *Connector Usage and Pin Assignments*

Harness side power connectors and all box/bracket-mounted connectors supplying power to other components should have female contacts.

Rationale: Unexposed power supply connector contacts preclude arcing, mismating, and contact shorting.

2.2.5.6 *Connector Function Separation*

Incompatible functions should be physically separated.

Rationale: A “standard” design practice to ensure connector conductor self-compatibility that precludes arcing and inductive current generation.

Best Practices for Hosted Payload Interface Design Guidelines Document		
Document No: BPHPID0001	Effective 3/23/2017	Version: DRAFT
		Page 14 of 60

2.2.5.7 *Connector Derating*

Instrument and Host Spacecraft should derate electrical connectors using *Electronic Parts, Materials, and Processes for Space and Launch Vehicles (MIL-HDBK-1547A)* as a guide.

Rationale: A “standard” design practice.

2.2.5.8 *Connector Access*

At least 50 mm of clearance should exist around the outside of mated connectors.

Rationale: Ensures the ability to perform proper connector mate/de-mate operations.

2.2.5.9 *Connector Engagement*

Connectors should be mounted to ensure straight and free engagement of the contacts.

Rationale: This precludes mismating connectors.

2.2.5.10 *Power Connector Type*

The Instrument power connectors should be space-flight qualified MIL-DTL-24308, Class M, Subminiature Rectangular connectors with standard density size 20 crimp contacts and conform to GSFC S-311-P-4/09.

Rationale: Connector sizes and types selected based upon familiarity, availability, and space flight qualification.

2.2.5.11 *Power Connector Size and Conductor Gauge*

The Instrument power connectors should be 20 AWG, 9 conductor (shell size 1) or 15 conductor (shell size 2) connectors.

Rationale: Application of stated design practices to the CII instrument power bus connectors.

2.2.5.12 *Power Connector Pin Out*

The Instrument power connectors should utilize the supply and return pin outs defined in Table 2-1 and identified in Figure 2-1 thru Figure 2-3.

Rationale: Application of stated design practices to the CII instrument power bus connectors.

Note: the connectors are depicted with the instrument side of the connector (pins) shown while the spacecraft side of the connector (sockets) is the mirror image.

Table 2-1: Instrument Power Connector Pin Out Definition

Power Bus	Circuit	Supply Conductor Position	Return Conductor Position
#1	A & B	11, 12, 13, 23, 24, 25	1, 2, 3, 14, 15, 16
#2	A & B	6, 7, 8, 13, 14, 15	1, 2, 3, 9, 10, 11
Survival Heater	A & B	4, 5, 8, 9	1, 2, 6, 7

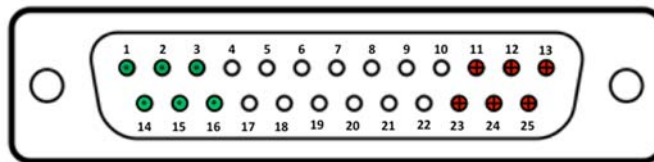

Figure 2-1: Instrument Side Power Bus #1 Circuit A & Circuit B

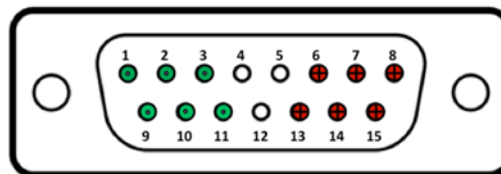

Figure 2-2: Instrument Side Power Bus #2 Circuit A & Circuit B

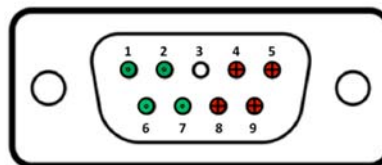

Figure 2-3: Instrument Side Survival Heater Power Bus Circuit A & Circuit B

2.2.5.13 *SpaceWire Connectors and Harnessing*

The Instrument SpaceWire harnessing and connectors should conform to ECSS-E-ST-50-12C.

Rationale: Describes the appropriate design practice for all SpaceWire connections and harnessing.

2.2.5.14 *Power Connector Provision*

The Instrument Provider should furnish all flight-quality instrument power mating connectors (Socket Side) to the Host Spacecraft Manufacturer for interface harness fabrication.

Rationale: Assigns “standard practice” responsibility.

Best Practices for Hosted Payload Interface Design Guidelines Document		
Document No: BPHPID0001	Effective 3/23/2017	Version: DRAFT
		Page 16 of 60

2.2.5.15 *Power Connector Conductor Size and Type*

The Instrument should have size 20 socket crimp contacts on the Instrument side power connectors and size 20 pin crimp contacts on the Host Spacecraft side power connectors.

Rationale: Application of the conductor size and type selected for the CII instrument power bus connectors to the corresponding instrument power connectors.

2.2.5.16 *Power Connector Keying*

The instrument power connectors should be keyed as defined in Figure 2-4.

Rationale: Application of stated design practices to the CII instrument power bus connectors.

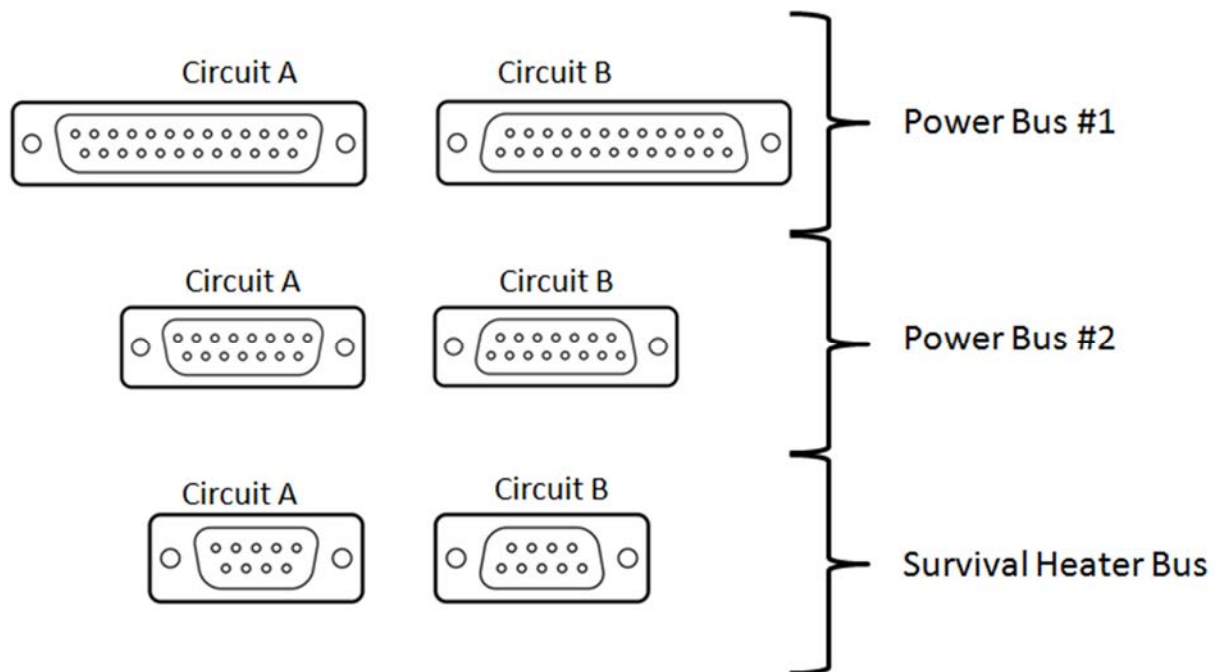

Figure 2-4: Power Connector Keying

2.2.5.17 *Connector Type Selection*

All connectors to be used by the Instrument should be selected from the Goddard Spaceflight Center (GSFC) Preferred Parts List (PPL).

Rationale: Utilizing the GSFC PPL simplifies connector selection, since all of its hardware is spaceflight qualified.

2.2.5.18 *Flight Plug Installation*

Flight plugs requiring installation prior to launch should be capable of being installed at the Host Spacecraft level.

Rationale: Ensures necessary access.

Best Practices for Hosted Payload Interface Design Guidelines Document		
Document No: BPHPID0001	Effective 3/23/2017	Version: DRAFT
		Page 17 of 60

2.2.5.19 *Test Connector Location and Types*

Test connector and coupler ports should be accessible without disassembly throughout integration of the Instrument and Host Spacecraft.

Rationale: This reduces the complexity and duration of integrated testing and simplifies preflight anomaly resolution.

2.3 Mechanical Interface Reference Material / Best Practices

2.3.1 Mass Centering

The Instrument center of mass should be less than 5 cm radial distance from the $Z_{instrument}$ axis, defined as the center of the Instrument mounting bolt pattern.

Rationale: Engineering analysis determined guideline Instrument mass centering parameters based on comparisons to the spacecraft envelope in the *STP-SIV Payload User's Guide*.

The Instrument center of mass should be located less than half of the Instrument height above the Instrument mounting plane.

Rationale: Engineering analysis determined guideline Instrument mass centering parameters based on comparisons to the spacecraft envelope in the *STP-SIV Payload User's Guide*.

2.3.2 Documentation of Mechanical Properties

2.3.2.1 *Envelope*

The MICD will document the Instrument component envelope (including kinematic mounts and MLI) as "not to exceed" dimensions.

Rationale: Defines the actual maximum envelope within which the instrument resides.

2.3.2.2 *Mass*

The MICD will document the mass of the Instrument, measured to $\pm 1\%$.

Rationale: To ensure that accurate mass data is provided for analytic purposes.

2.3.2.3 *Center of Mass*

The MICD will document the launch and on-orbit centers of mass of each Instrument, references to the Instrument coordinate axes and measured to ± 5 mm.

Rationale: To ensure that accurate CG data is provided for analytic purposes.

2.3.2.4 *Moment of Inertia*

The MICD will document the moments of inertia, measured to less than 10%

Rationale: To ensure that accurate moments of inertia data is provided for analytic purposes.

Best Practices for Hosted Payload Interface Design Guidelines Document		
Document No: BPHPID0001	Effective 3/23/2017	Version: DRAFT
		Page 18 of 60

2.3.2.5 *Constraints on Moments of Inertia*

The MICD will document the constraints to the moments and products of inertia available to the Instrument.

Rationale: To define the inertial properties envelope within which the Instrument may operate and not adversely affect Host Spacecraft and primary instrument operations.

2.3.3 Dynamic Properties

Documentation of Dynamic Envelope or Surfaces

The MICD will document the initial and final configurations, as well as the swept volumes of any mechanisms that cause a change in the external envelope or external surfaces of the Instrument.

Rationale: To define variations in envelope caused by deployables.

2.3.3.1 *Documentation of Dynamic Mechanical Elements*

The MICD will document the inertia variation of the Instrument due to movable masses, expendable masses, or deployables.

Rationale: Allows Host Spacecraft Manufacturer to determine the impact of such variations on Host Spacecraft and primary payload.

2.3.3.2 *Caging During Test and Launch Site Operations*

Instrument mechanisms that require caging during test and launch site operations should cage when remotely commanded.

Rationale: To allow proper instrument operation during integration and test.

Instrument mechanisms that require uncaging during test and launch site operations should uncage when remotely commanded.

Rationale: To allow proper instrument operation during integration and test.

Instrument mechanisms that require caging during test and launch site operations should cage when accessible locking devices are manually activated.

Rationale: To allow proper instrument operation during integration and test.

Instrument mechanisms that require uncaging during test and launch site operations should uncage when accessible unlocking devices are manually activated.

Rationale: To allow proper instrument operation during integration and test.

Best Practices for Hosted Payload Interface Design Guidelines Document		
Document No: BPHPID0001	Effective 3/23/2017	Version: DRAFT
		Page 19 of 60

2.3.4 Instrument Mounting

2.3.4.1 *Documentation of Mounting*

The MICD will document the mounting interface, method, and geometry, including ground strap provisions and dimensions of the holes for mounting hardware.

Rationale: To ensure no ambiguity of mounting interface between instrument and spacecraft.

2.3.4.2 *Documentation of Instrument Mounting Location*

The MICD will document the mounting location of the Instrument on the Host Spacecraft.

Rationale: To ensure no ambiguity of mounting location on spacecraft.

2.3.4.3 *Metric Units*

The MICD will specify whether mounting fasteners will conform to SI or English unit standards.

Rationale: Metric hardware are not exclusively used industry wide. Choice of unit system likely will be set by spacecraft manufacturer.

2.3.4.4 *Documentation of Finish and Flatness Guidelines*

The MICD will document finish and flatness guidelines for the mounting surfaces.

Rationale: To ensure no ambiguity of finish and flatness requirements at instrument interface.

2.3.4.5 *Drill Template Usage*

The MICD will document the drill template details and serialization.

Rationale: Drill template details will be on record.

The Instrument Developer should drill spacecraft and test fixture interfaces using the MICD defined template.

Rationale: A common drill template will ensure proper alignment and repeatability of mounting holes.

2.3.4.6 *Kinematic Mounts*

The Instrument Provider should provide all kinematic mounts.

Rationale: If the instrument requires kinematic mounts, they should be the responsibility of the instrument provider due to their knowledge of the instrument performance requirements.

2.3.4.7 *Fracture Critical Components of Kinematic Mounts*

Kinematic mounts should comply with all analysis, design, fabrication, and inspection requirements associated with fracture critical components as defined by NASA-STD-5019.

Best Practices for Hosted Payload Interface Design Guidelines Document		
Document No: BPHPID0001	Effective 3/23/2017	Version: DRAFT
		Page 20 of 60

Rationale: Kinematic mount failure is a potential catastrophic hazard to the Instrument and the Host Spacecraft.

2.3.5 Instrument Alignment

2.3.5.1 *Documentation of Coordinate System*

The MICD will document the Instrument Reference Coordinate Frame.

Rationale: To ensure there is no ambiguity between Instrument Developer and Host Spacecraft Manufacturer regarding the Instrument Reference Coordinate System.

2.3.5.2 *Instrument Interface Alignment Cube*

If the Instrument has critical alignment requirements, the Instrument should contain an Interface Alignment Cube (IAC), an optical cube that aligns with the Instrument Reference Coordinate Frame.

Rationale: To aid in proper alignment of the Instrument to the Host Spacecraft during Integration and Test, assuming that the spacecraft provides access to its own IAC.

2.3.5.3 *Interface Alignment Cube Location*

The Instrument Developer should mount the IAC such that it is visible at all stages of integration with the Host Spacecraft from at least two orthogonal directions.

Rationale: Observation of IAC from at least two directions is required for alignment.

2.3.5.4 *Interface Alignment Cube Documentation*

The MICD will document the location of all optical alignment cubes on the Instrument.

Rationale: To have a record of the IAC locations.

2.3.5.5 *Instrument Boresight*

The Instrument Developer should measure the alignment angles between the IAC and the Instrument boresight.

Rationale: Since this knowledge is critical to the Instrument Developer, they should be responsible for taking the measurement.

The MICD will document the alignment angles between the IAC and the Instrument boresight.

Rationale: To record the actual alignment angle in case it is needed for later analysis.

2.3.5.6 *Pointing Accuracy, Knowledge, and Stability*

The MICD will document the Host Spacecraft required pointing accuracy, knowledge, and stability capabilities in order for the Instrument to meet its operational requirements.

Best Practices for Hosted Payload Interface Design Guidelines Document		
Document No: BPHPID0001	Effective 3/23/2017	Version: DRAFT
		Page 21 of 60

Rationale: To establish that Host Spacecraft pointing accuracy, knowledge and stability specifications meet requirements of instrument operation.

2.3.6 Integration and Test

2.3.6.1 *Installation/Removal*

The Instrument should be capable of being installed or removed in its launch configuration without disturbing the primary payload.

Rationale: Primary payload safety.

2.3.6.2 *Mechanical Attachment Points*

The Instrument should provide mechanical attachment points that will be used by a handling fixture during integration of the instrument.

Rationale: The handling fixtures will be attached to the Instrument while in the Integration and Test environment.

The MICD will document details of the mechanical attachment points used by the handling fixture.

Rationale: To ensure handling fixture attachment points are properly recorded.

2.3.6.3 *Load Margins*

Handling and lifting fixtures should function according to their operational specifications at five (5) times limit load for ultimate.

Handling and lifting fixtures should function according to their operational specifications at three (3) times limit load for yield.

Handling fixtures should be tested to two (2) times working load.

Rationale: All three load margins maintain personnel and instrument safety.

2.3.6.4 *Responsibility for Providing Handling Fixtures*

The Instrument Provider should provide proof-tested handling fixtures for each component with mass in excess of 16 kg.

Rationale: This guideline protects personnel safety.

2.3.6.5 *Accessibility of Red Tag Items*

All items intended for pre-flight removal from the Instrument should be accessible without disassembly of another Instrument component.

Rationale: Instrument safety.

Best Practices for Hosted Payload Interface Design Guidelines Document		
Document No: BPHPID0001	Effective 3/23/2017	Version: DRAFT
		Page 22 of 60

2.3.6.6 *Marking and Documentation of Test Points and Test Guidelines*

All test points and Integration and Test (I&T) interfaces on the Instrument should be visually distinguishable from other hardware components to an observer standing 4 feet away.

Rationale: Clear visual markings mitigate the risk that Integration and test personnel will attempt to connect test equipment improperly, leading to Instrument damage. Four feet exceeds the length of most human arms and ensures that a technician would see any markings on hardware before connecting test equipment.

The MICD will document all test points and test guidelines.

Rationale: To ensure no ambiguity of Integration and Test interfaces and test points and to aide in developing I&T procedures.

2.3.6.7 *Orientation Constraints During Test*

The MICD will document instrument mechanisms, thermal control, or any exclusions to testing and operations related to orientations.

Rationale: This documents any exceptions to the 1g functionality described in section **Error! Reference source not found.**

2.3.6.8 *Temporary Items*

All temporary items to be removed following test should be visually distinguishable from other hardware components to an observer standing 4 feet away.

Rationale: Any preflight removable items need to be obvious to casual inspection to mitigate the risk of them causing damage or impairing spacecraft functionality during launch/operations.

The MICD will document all items to be installed prior to or removed following test and all items to be installed or removed prior to flight.

Rationale: To ensure no ambiguity of installed and/or removed items during Integration and Test through documentation.

2.3.6.9 *Temporary Sensors*

The Instrument should accommodate temporary installation of sensors and supporting hardware for use during environmental testing.

Rationale: To facilitate environmental testing.

Examples include optical simulators, acceleration sensors, and thermal monitors.

Best Practices for Hosted Payload Interface Design Guidelines Document		
Document No: BPHPID0001	Effective 3/23/2017	Version: DRAFT
		Page 23 of 60

2.3.6.10 *Captive Hardware*

The Instrument Developer should utilize captive hardware for all items planned to be installed, removed, or replaced during integration, except for Instrument mounting hardware and MLI.

Rationale: Captive hardware reduces the danger to the Host Spacecraft, Instrument, and personnel from fasteners dropped during integration.

2.3.6.11 *Venting Documentation*

The MICD will document the number, location, size, vent path, and operation time of Instrument vents.

Rationale: This eliminates ambiguity regarding venting the Instrument and how it may pertain to the Host Spacecraft and primary instrument operations.

2.3.6.12 *Non-Destructive Evaluation*

Kinematic mount flight hardware should show no evidence of micro cracks when inspected using Non-Destructive Evaluation (NDE) techniques following proof loading.

Rationale: To ensure kinematic mounts meet load requirements without damage.

2.4 Thermal Interface Reference Material / Best Practices

2.4.1 Heat Management Techniques

2.4.1.1 *Heat Transfer Hardware*

The Instrument Developer should consider implementing heat pipes and high thermal conductivity straps to transfer heat within the Instrument.

Rationale: A Host Spacecraft would likely more easily accommodate an Instrument whose thermal design is made more flexible by the inclusion of heat transfer hardware.

The payload designer should expect some amount of spacecraft backloading on the payload radiators, especially those operating at very low temperatures. The backloading on the radiators depends on the temperature of the source and the view factor between the source and the payload radiator. A radiator running 10° C can have as much as 25 W/sq m from spacecraft component at 50° C and having a 0.1 View Factor. One approach to avoid this backloading is to locate the radiator on a surface which will have least exposure to solar panels. This may require using heat pipes to transfer the waste heat to radiators.

2.4.1.2 *Survivability at Very Low Temperature*

The Instrument Developer should consider using components that can survive at -55° C to minimize the survival power demands on the Host Spacecraft.

Best Practices for Hosted Payload Interface Design Guidelines Document		
Document No: BPHPID0001	Effective 3/23/2017	Version: DRAFT
		Page 24 of 60

Rationale: -55° C is a common temperature to which space components are certified. The use of components certified to this temperature decreases the survival heater power demands placed upon the Host Spacecraft.

2.4.1.3 *Implementation of Cooling Function*

The Instrument Developer should consider implementing thermoelectric coolers or mechanical coolers if cryogenic temperatures are required for the instrument to minimize the restrictions on Instrument radiator orientations.

Rationale: Thermoelectric or mechanical coolers provide an alternative technique to achieve very low temperatures that do not impose severe constraints on the placement of the radiator.

2.4.1.4 *Implementation of High Thermal Stability*

The Instrument Developer should consider implementing high thermal capacity hardware, such as phase change material, in order to increase the Instrument's thermal stability.

Rationale: Some optical instruments require very high thermal stability and given the relatively low masses expected in CII Instruments, incorporating phase change material for thermal storage is a useful technique.

2.4.2 Survival Heaters

The use of survival heaters is a technique to autonomously apply heat to an Instrument in the event that the thermal subsystem does not perform nominally, either due to insufficient power from the Host Spacecraft or an inflight anomaly.

2.4.2.1 *Survival Heater Responsibility*

The Instrument Provider should provide and install all Instrument survival heaters.

Rationale: Survival heaters are a component of the Instrument.

2.4.2.2 *Mechanical Thermostats*

The Instrument should control Instrument survival heaters via mechanical thermostats.

Rationale: Mechanical thermostat allows control of the survival heaters while the instrument avionics are not operating.

2.4.2.3 *Survival Heater Documentation*

The TICD will document survival heater characteristics and mounting details.

Rationale: This will capture the agreements negotiated by the Host Spacecraft Manufacturer and Instrument Developer.

2.4.2.4 *Minimum Turn-On Temperatures*

The Instrument should maintain the temperature of its components at a temperature no lower than that required to safely energize and operate the components.

Best Practices for Hosted Payload Interface Design Guidelines Document		
Document No: BPHPID0001	Effective 3/23/2017	Version: DRAFT
		Page 25 of 60

Rationale: Some electronics require a minimum temperature in order to safely operate.

2.4.3 *Thermal Performance and Monitoring*

2.4.3.1 *Surviving Arbitrary Pointing Orientations*

The Instrument should be capable of surviving arbitrary pointing orientations without permanent degradation of performance for a minimum of four (4) orbits with survival power only.

Rationale: This is a typical NASA earth orbiting science instrument survival requirement.

2.4.3.2 *Documentation of Temperature Limits*

The TICD will document temperature limits for Instrument components during ground test and on-orbit scenarios.

Rationale: This will provide values for the Integration and Test technicians to monitor and manage.

2.4.3.3 *Documentation of Monitoring Location*

The TICD will document the location of all Instrument temperature sensors.

Rationale: This is the standard means to documents the agreement between the Host Spacecraft and Instrument.

2.4.3.4 *Temperature Monitoring During OFF Mode*

The Instrument Designer should assume that the Host Spacecraft will monitor only one temperature on the spacecraft side of the payload interface when the payload is off. During extreme cases such as host anomalies, however, even this temperature might not be available.

Rationale: This limits the demands that the Instrument may place on the Host Spacecraft.

2.4.3.5 *Thermal Control Hardware Documentation*

The TICD will document Instrument Developer-provided thermal control hardware.

Rationale: This is the standard means to documents the agreement between the Host Spacecraft and Instrument.

2.4.3.6 *Thermal Performance Verification*

The Instrument Developer should verify the Instrument thermal control system ability to maintain hardware within allowable temperature limits either empirically by thermal balance testing or by analysis for conditions that cannot be ground tested.

Rationale: These verification methods ensure that the Instrument's thermal performance meets the guidelines and agreements documented in the TICD.

Best Practices for Hosted Payload Interface Design Guidelines Document		
Document No: BPHPID0001	Effective 3/23/2017	Version: DRAFT
		Page 26 of 60

2.5 Environmental Reference Material / Best Practices

2.5.1 Radiation-Induced SEE

The following best practices describe how the Instrument should behave in the event that a radiation-induced SEE does occur.

2.5.1.1 *Temporary Loss of Function or Loss of Data*

Temporary loss of function or loss of data is permitted, provided that the loss does not compromise Instrument or Host Spacecraft health and full performance can be recovered rapidly.

Rationale: Identifies that a temporary loss of function and/or data is permissible in support of correcting anomalous operations. This includes autonomous detection and correction of anomalous operations as well as power cycling.

2.5.1.2 *Restoration of Normal Operation and Function*

To minimize loss of data, normal operation and function should be restored via internal correction methods without external intervention.

Rationale: Identifies that autonomous fault detection and correction should be implemented.

2.5.1.3 *Irreversible Actions*

Irreversible actions should not be permitted. The hardware design should have no parts which experience radiation induced latch-up to an effective LET of 75 MeV/mg/cm² and a fluence of 10⁷ ions/cm².

Rationale: Identifies limitations for radiation induced latch-up and prescribes both a LET and an ion fluence immunity level

2.6 Software Engineering Reference Material / Best Practices

The Instrument System's software should comply with Class C software development requirements and guidelines, in accordance with NPR 7150.2A

Rationale: NPR 7150.2A Appendix E assigns Class C to "flight or ground software that is necessary for the science return from a single (non-primary) instrument." NASA Class C software is any flight or ground software that contributes to mission objectives, but whose correct functioning is not essential to the accomplishment of primary mission objectives. In this context, primary mission objectives are exclusively those of the Host Spacecraft.

2.7 Contamination Reference Material / Best Practices

2.7.1 Assumptions

During the Instrument-to-Host Spacecraft pairing process, the Host Spacecraft Owner/Integrator and the Instrument Developer will negotiate detailed parameters

Best Practices for Hosted Payload Interface Design Guidelines Document		
Document No: BPHPID0001	Effective 3/23/2017	Version: DRAFT
		Page 27 of 60

regarding contamination control. The Contamination Interface Control Document (CICD) will record those parameters and decisions.

The Instrument Developer will ensure that any GSE accompanying the Instrument is cleanroom compatible in accordance with the CICD.

The Instrument Developer will ensure that any GSE accompanying the Instrument into a vacuum chamber during Host Spacecraft thermal-vacuum testing is vacuum compatible in accordance with the CICD.

The Host Spacecraft Manufacturer/Systems Integrator will attach the Instrument to the Host Spacecraft such that the contamination products from the vents of the Instrument do not directly impinge on the contamination-sensitive surfaces nor directly enter the aperture of another component of the Host Spacecraft system.

The Host Spacecraft Manufacturer/Systems Integrator will install protective measures as provided by the Instrument Provider to protect sensitive Instrument surfaces while in the Shipment, Integration and Test, and Launch environments.

The Launch Vehicle Provider will define the upper limit for the induced contamination environment. This is typically defined as the total amount of molecular and particulate contamination deposited on exposed spacecraft surfaces from the start of payload fairing encapsulation until the upper stage separation and contamination collision avoidance maneuver (CCAM).

2.7.2 Instrument Generated Contamination

2.7.2.1 *Verification of Cleanliness*

The Instrument Developer should verify by test the cleanliness of the instrument exterior surfaces documented in the CICD, prior to delivery to the Host Spacecraft Manufacturer/Systems Integrator.

Rationale: The Instrument must meet surface cleanliness requirements that are consistent with the cleanliness requirements as specified for the Host Spacecraft by the Spacecraft Manufacturer. A record of the cleanliness verification should be provided to the Host Spacecraft Manufacturer prior to Instrument integration with the Host Spacecraft.

2.7.2.2 *Instrument Sources of Contamination*

The CICD will document all sources of contamination that can be emitted from the Instrument.

Rationale: This determines the compatibility of the Instrument with the Host Spacecraft and mitigates the risk of Instrument-to-Host-Spacecraft cross contamination.

2.7.2.3 *Instrument Venting Documentation*

The CICD will document the number, location, size, vent path, and operation time of all Instrument vents.

Best Practices for Hosted Payload Interface Design Guidelines Document		
Document No: BPHPID0001	Effective 3/23/2017	Version: DRAFT
		Page 28 of 60

Rationale: Mitigation of Instrument-to-Host-Spacecraft cross contamination (See 2.7.2.2)

2.7.2.4 *Flux of outgassing products*

The CCID will document the flux (g/cm²/s) of outgassing products issuing from the primary Instrument vent(s).

Rationale: Mitigation of Instrument-to-Host-Spacecraft cross contamination (See 2.7.2.2)

2.7.2.5 *Sealed Hardware*

The Instrument should prevent the escape of actuating materials from Electro-explosive devices (EEDs), hot-wax switches, and other similar devices.

Rationale: Mitigation of Instrument-to-Host-Spacecraft cross contamination (See 2.7.2.2)

2.7.2.6 *Nonmetallic Materials Selection*

The Instrument design should incorporate only those non-metallic materials that meet the nominal criteria for thermal-vacuum stability: Total Mass Loss (TML) ≤ 1.0 %, Collected Volatile Condensable Material (CVC) ≤ 0.1 %, per ASTM E595 test method.

Rationale: Host Spacecraft Manufacturers generally require that all nonmetallic materials conform to the nominal criteria for thermal-vacuum stability. A publicly accessible database of materials tested per ASTM E595 is available at: outgassing.nasa.gov Note: Some Host Spacecraft Manufacturers may require lower than the nominal levels of TML and CVC.

2.7.2.7 *Wiring and MLI Cleanliness Guidelines*

The CCID will document thermal vacuum bakeout requirements for Instrument wiring harnesses and MIL.

Rationale: Thermal vacuum conditioning of materials and components may be necessary to meet Host Spacecraft contamination requirements.

2.7.2.8 *Particulate Debris Generation*

The Instrument design should avoid the use of materials that are prone to produce particulate debris.

Rationale: Host Spacecraft Manufacturers generally prohibit materials that are prone to produce particulate debris, either from incidental contact or through friction or wear during operation. Therefore, such materials, either in the construction of the payload or ground support equipment, should be avoided. Where no suitable alternative material is available, an agreement with the Host Spacecraft will be necessary and a plan to mitigate the risk posed by the particulate matter implemented.

Best Practices for Hosted Payload Interface Design Guidelines Document		
Document No: BPHPID0001	Effective 3/23/2017	Version: DRAFT
		Page 29 of 60

2.7.2.9 *Spacecraft Integration Environments*

The Instrument should be compatible with processing in environments ranging from IEST-STD-1246 ISO-6 to ISO-8.

Rationale: Host Spacecraft integration facilities may vary in cleanliness and environmental control capabilities depending on the Host Spacecraft Manufacturer and integration/test venue. Instruments and associated ground support equipment should be compatible with protocols contamination control of ISO-6 cleanroom environments. Instruments should be compatible with operations in up to ISO-8 environments, employing localized controls such as bags, covers, and purges to preserve cleanliness; such controls must be integrated into the Host Spacecraft integrations process.

2.7.3 Accommodation of Externally Generated Contamination

2.7.3.1 *Protective Covers: Responsibility*

The Instrument Developer should provide protective covers for any contamination-sensitive components of the Instrument.

Rationale: Preservation of Instrument cleanliness during Host Spacecraft I&T.

2.7.3.2 *Protective Covers: Documentation*

The CICD will document the requirements and procedures for the use of protective covers (such as bags, draping materials, or hardcovers).

Rationale: Preservation of Instrument cleanliness during Host Spacecraft I&T.

2.7.3.3 *Instrument Cleanliness Requirements*

The CICD will document the cleanliness goals for all contamination-sensitive instrument surfaces that will be exposed while in the Integration and Test Environment.

Rationale: Enables the Spacecraft Manufacturer and Instrument Provider to negotiate appropriate and reasonable instrument accommodations or determine the degree of deviation from the defined goals.

2.7.4 Instrument Purge Requirements

The CICD will document Instrument purge requirements, including type of purge gas, flow rate, gas purity specifications, filter pore size, type of desiccant (if any), and whether interruptions in the purge are tolerable.

Rationale: The Host Spacecraft Manufacturer generally will provide access to a gas supply of the desired type, purity, and flow rate. The Instrument provider is responsible to provide the necessary purge interface ground support equipment (See 2.7.4.1).

Best Practices for Hosted Payload Interface Design Guidelines Document		
Document No: BPHPID0001	Effective 3/23/2017	Version: DRAFT
		Page 30 of 60

2.7.4.1 *Instrument Purge Ground Support Equipment (GSE)*

The Instrument Provider should provide purge ground support equipment (GSE) incorporating all necessary filtration, gas conditioning, and pressure regulation capabilities.

Rationale: The Instrument provider is responsible for control of the gas input to the instrument during Host Spacecraft Integration & Test. This purge GSE is the interface between the Instrument and the gas supply provided by the Spacecraft Manufacturer.

2.7.4.2 *Spacecraft to Instrument Purge Interface*

The MICD will document any required mechanical interface of the Instrument purge between the Instrument and Host Spacecraft.

Rationale: The MICD is used to document agreements concerning the mechanical interface. The Host Spacecraft Manufacturer will negotiate with the Launch Vehicle Provider any resultant required purge interface between the Host Spacecraft and Launch Vehicle.

2.7.4.3 *Instrument Inspection and Cleaning During I&T: Responsibility*

The Instrument Provider should be responsible for cleaning the Instrument while in the Integration and Test Environment.

Rationale: The Instrument Provider is responsible for completing any required inspections during I&T. The Instrument Provider may, upon mutual agreement, designate a member of the Host Spacecraft I&T team to perform inspections and cleaning.

2.7.4.4 *Instrument Inspection and Cleaning During I&T: Documentation*

The CICD will document any required inspection or cleaning of the Instrument while in the Integration and Test Environment.

Rationale: Instrument inspections and cleaning consume schedule resources and must be conducted in coordination with other Spacecraft I&T activities.

2.7.4.5 *Spacecraft Contractor Supplied Analysis Inputs*

The CICD will document the expected Host Spacecraft-induced contamination environment.

Rationale: Mitigate the risk of Instrument-Host Spacecraft cross contamination. The Host Spacecraft Manufacturer may perform analyses or make estimates of the expected spacecraft-induced contamination environment, which will be documented in CICD. The results of such assessments may include a quantitative estimate of the deposition of plume constituents to Instrument surfaces and be used to determine the allowable level of contamination emitted from the Instrument.

Best Practices for Hosted Payload Interface Design Guidelines Document		
Document No: BPHPID0001	Effective 3/23/2017	Version: DRAFT
		Page 31 of 60

2.7.4.6 *Launch Vehicle Contractor Supplied Analysis Inputs*

The CICD will document the Launch Vehicle-induced contamination environment

Rationale: Most Launch Vehicle Providers are able to provide nominal information regarding the upper bound of molecular and particulate contamination imparted to the Spacecraft Payload surfaces; frequently such information is found in published User Guides for specific Launch Vehicles. Host Spacecraft Manufacturers and Instrument Developers should use this information in developing mitigations against the risk of contamination during integrated operations with the Launch Vehicle.

2.8 Model Guidelines and Submittal Details

2.8.1 Finite Element Model Submittal

The Instrument Developer should supply the Host Spacecraft Manufacturer with a Finite Element Model in accordance with the GSFC GIRD.

Rationale: The GIRD defines a NASA Goddard-approved interface between the Earth Observing System Common Spacecraft and Instruments, including requirements for finite element models. As of the publication of this guideline document, Gird Rev B is current, and the Finite Element Model information is in Section 11.1.

2.8.2 Thermal Math Model

The Instrument Developer should supply the Host Spacecraft Manufacturer with a reduced node geometric and thermal math model in compliance with the following sections.

Rationale: The requirements and details for the Thermal Model submittal listed in this section are based on commonly used NASA documents such as GSFC GIRD and JPL spacecraft instrument interface requirement documents.

2.8.2.1 *Model Format*

Model format should be in Thermal Desktop version 5.2 or later or NX Space Systems Thermal version 7.x or later.

2.8.2.2 *Units of Measure*

The MICD will specify model units of measure.

2.8.2.3 *Radiating Surface Element Limit*

Radiating surface elements should be limited to less than 200.

2.8.2.4 *Thermal Node Limit*

Thermal nodes should be limited to less than 500.

2.8.2.5 *Model Verification*

The Geometric Math Model and Thermal Math Model should be documented with a benchmark case in which the Host Spacecraft Manufacturer may use to verify the model run.

Best Practices for Hosted Payload Interface Design Guidelines Document		
Document No: BPHPID0001	Effective 3/23/2017	Version: DRAFT
		Page 32 of 60

2.8.2.6 *Steady-State and Transient Analysis*

The model should be capable of steady-state and transient analysis.

2.8.2.7 *Reduced Node Thermal Model Documentation*

The Instrument Provider should supply the Spacecraft Developer with documentation describing the reduced node thermal model. The documentation should contain the following:

- 1) Node(s) Location: the node(s) location at which each temperature limit applies.
- 2) Electrical Heat Dissipation: a listing of electrical heat dissipation and the node(s) where applied.
- 3) Active Thermal Control: a listing of active thermal control, type of control (*e.g.*, proportional heater), and the node(s) where applied.
- 4) Boundary Notes: a listing and description of any boundary nodes used in the model.
- 5) Environmental Heating: a description of the environmental heating (Beta angle, heliocentric distance, planetary albedo, planetary emissive power, *etc.*).
- 6) User Generated Logic: a description of any user generated software logic

2.8.3 Thermal Analytical Models

The Instrument Provider should furnish the Spacecraft Manufacturer with a written report documenting the results of the detailed thermal analysis and the comparison of results to the reduced node model, including a high-level energy balance and heat flow map.

2.8.4 Mechanical CAD Model

2.8.4.1 *Model Format*

The Instrument Provider should provide Mechanical CAD models in a file format compatible with the Host Spacecraft Manufacturer-specified CAD applications or in a neutral file format, such as IGES or STEP.

Rationale: The Host Spacecraft Manufacturer may need Mechanical CAD models for hosted payload assessment studies.

Best Practices for Hosted Payload Interface Design Guidelines Document		
Document No: BPHPID0001	Effective 3/23/2017	Version: DRAFT
		Page 33 of 60

2.8.5 Mass Model

2.8.5.1 *Instrument Mass Model*

The Instrument Provider should provide all physical mass models required for spacecraft mechanical testing.

Rationale: The Host Spacecraft Manufacturer may fly the mass model in lieu of the Instrument in the event that Instrument delivery is delayed.

Best Practices for Hosted Payload Interface Design Guidelines Document		
Document No: BPHPID0001	Effective 3/23/2017	Version: DRAFT
		Page 34 of 60

3.0 BEST PRACTICES FOR GEO

3.1 Data Interface Reference Material / Best Practices

3.1.1 CCSDS Data Transmission

The Instrument should transmit and receive all packet data using Consultative Committee for Space Data Systems (CCSDS) primary and secondary headers for packet sequencing and control.

Rationale: The use of CCSDS packets for data communication is common practice across aerospace flight and ground data systems.

3.1.2 Flight Software Update

Instrument control flight software should be updatable on orbit through ground command.

Rationale: On-orbit flight software updates are a best practice that facilitates improvements and/or workarounds deemed necessary through operational experience.

3.1.3 Flight Software Update (Partial)

Individual memory addresses of instrument control software should be updatable on orbit through ground command.

Rationale: On-orbit flight software updates are a best practice that facilitates improvements and/or workarounds deemed necessary through operational experience.

3.1.4 Use of Preexisting Communication Infrastructure

As a best practice, Instrument Developers should consider utilizing the communication infrastructure provided by the Host Spacecraft and Satellite Operator for all of the Instrument's space-to-ground communications needs.

Rationale: The size, mass, and power made available to the Instrument may not simultaneously accommodate a scientific Instrument as well as communications terminals, antennas, and other equipment. Additionally, the time required for the Instrument Developer to apply for and secure a National Telecommunications and Information Administration (NTIA) Spectrum Planning Subcommittee (SPS) Stage 4 (operational) Approval to transmit on a particular radio frequency band may exceed the schedule available, given the constraints as a hosted payload. A Satellite Operator will have already initiated the spectrum approval process that would cover any data the Instrument transmits through the Host Spacecraft. NPR 2570.1B, *NASA Radio Frequency (RF) Spectrum Management Manual*, details the spectrum approval process for NASA missions.

3.2 Electrical Power Interface Reference Material / Best Practices

Note: This section assumes that the Host Spacecraft will provide access to its Electrical Power System using the interface defined in Section **Error! Reference source not found.**

Best Practices for Hosted Payload Interface Design Guidelines Document		
Document No: BPHPID0001	Effective 3/23/2017	Version: DRAFT
		Page 35 of 60

3.2.1 Electrical Interface Definitions

3.2.1.1 *Power Bus Current Rate of Change*

For power bus loads with current change greater than 2 A, the rate of change of current should not exceed 500 mA/ μ s.

Rationale: This describes the maximum nominal rate of change for instrument electrical current to bound nominal and anomalous behavior.

3.2.1.2 *Power Bus Isolation*

All Instrument power buses (both operational and survival) should be electrically isolated from each other and from the chassis.

Rationale: Circuit protection and independence.

3.2.1.3 *Power Bus Returns*

All Instrument power buses (both operational and survival heater) should have independent power returns.

Rationale: Circuit protection and independence.

3.2.2 Survival Heaters

3.2.2.1 *Survival Heater Power Bus Circuit Failure*

The Instrument survival heater circuit should prevent a stuck-on condition of the survival heaters due to internal failures.

Rationale: A stuck-on survival heater could lead to excessive power draw and/or over-temperature events in the Instrument or Host Spacecraft. This is normally accomplished by using series-redundant thermostats in each survival heater circuit.

3.2.2.2 *Survival Heater Power Bus Heater Type*

The Instrument should use only resistive heaters (and associated thermal control devices) to maintain the Instrument at survival temperature when the main power bus is disconnected from the Instrument.

Rationale: This preserves the survival heater power bus for exclusive use of resistive survival heaters, whose function is to maintain the Instrument at a minimum turn-on temperature when the Instrument Power Buses are not energized.

3.2.2.3 *Survival Heater Power Bus Design*

The system design should allow enabling of both primary and redundant survival heater circuits without violating any thermal or power requirement.

Best Practices for Hosted Payload Interface Design Guidelines Document		
Document No: BPHPID0001	Effective 3/23/2017	Version: DRAFT
		Page 36 of 60

Rationale: This precludes excessive power draw and/or over-temperature events in the Instrument or Host Spacecraft. This is normally accomplished via the application of thermostats with different set points in each redundant survival heater circuit.

3.2.3 Voltage and Current Transients

3.2.3.1 *Low Voltage Detection*

A voltage excursion that causes the spacecraft Primary Power Bus to drop below 22 VDC in excess of four seconds constitutes an under-voltage condition. In the event of an under-voltage condition, the Host Spacecraft will shed various loads without delay, including the Instrument. A ground command should be required to re-power the loads, including the Instrument

Rationale: Bounds nominal and anomalous design conditions. Describes “typical” spacecraft CONOPS to the noted anomaly for application to design practice.

3.2.3.2 *Bus Undervoltage and Overvoltage Transients*

Derating factors should take into account the stresses that components are subjected to during periods of undervoltage or overvoltage, including conditions which arise during ground testing, while the bus voltage is slowly increased to its nominal value.

Rationale: This design feature describes a “standard” design practice.

3.2.3.3 *Bus Undervoltage and Overvoltage Transients Response*

The Instrument should not generate a spurious response that can cause equipment damage or otherwise be detrimental to the spacecraft operation during bus voltage variation, either up or down, at ramp rates below the limits specified in the sections below, and over the full range from zero to maximum bus voltage.

Rationale: The Instrument must tolerate appropriate electrical transients without affecting the Host Spacecraft.

3.2.3.4 *Abnormal Transients Undervoltage*

An abnormal undervoltage transient event is defined as a transient decrease in voltage on the Power Bus to no less than +10 VDC, maintaining the decreased voltage for no more than 10 ms, and returning to its previous voltage in less than 200 ms.

Rationale: The Instrument must tolerate the abnormal voltage transients, which can be expected to occur throughout its mission lifetime.

3.2.3.5 *Abnormal Transients Tolerance*

The Instrument should ensure that overstress does not occur to the unit during a transient undervoltage event.

Best Practices for Hosted Payload Interface Design Guidelines Document		
Document No: BPHPID0001	Effective 3/23/2017	Version: DRAFT
		Page 37 of 60

Rationale: The Instrument must tolerate the abnormal voltage transients, which can be expected to occur throughout its mission lifetime.

3.2.3.6 *Abnormal Transients Recovery*

Units which shut-off during an undervoltage should be capable of returning to a nominal power-up state at the end of the transient.

Rationale: The Instrument needs to tolerate the abnormal voltage transients, which can be expected to occur throughout its mission lifetime.

3.2.3.7 *Abnormal Transients Overvoltage*

An overvoltage transient event is defined as an increase in voltage on the Power Bus to no greater than +40 VDC, maintaining the increased voltage for no more than 10 ms, and returning to its previous voltage in less than 200 ms.

Rationale: A necessary definition of an Abnormal Transient Overvoltage

3.2.3.8 *Instrument Initial In-rush Current*

After application of +28 VDC power at t_0 , the initial inrush (charging) current due to distributed capacitance, EMI filters, etc., should be completed in 10 μ s with its peak no greater than 10 A.

Rationale: Bounds nominal and anomalous behavior.

3.2.3.9 *Instrument Initial In-rush Current Rate of Change*

The rate of change of inrush current after the initial application of +28V power should not exceed 20 mA/ μ s.

Rationale: Bounds nominal and anomalous behavior.

3.2.3.10 *Instrument In-rush Current after 10 μ s*

After 10 μ s, the transient current peak should not exceed three times the maximum steady state current.

Rationale: Bounds nominal and anomalous behavior.

3.2.3.11 *Instrument Steady State Operation*

Steady state operation should be attained within 50 ms from turn-on or transition to OPERATION mode, except for motors.

Rationale: Bounds nominal and anomalous behavior with a maximum transient duration of 50 ms.

Best Practices for Hosted Payload Interface Design Guidelines Document		
Document No: BPHPID0001	Effective 3/23/2017	Version: DRAFT
		Page 38 of 60

3.2.3.12 *Instrument Turn-off Peak Voltage Transients*

The peak voltage of transients generated on the Instrument side of the power relay caused by inductive effects of the load should fall within the -2 VDC to +40 VDC range.

Rationale: Bounds nominal behavior.

3.2.3.13 *Instrument Turn-off Transient Suppression*

The Instruments should use suppression devices, such as diodes, across all filter inductors, relay coils, or other energy sources that could induce transients on the power lines during turn-off.

Rationale: Describes design “standard practice.”

3.2.3.14 *Reflected Ripple Current – Mode Changes*

The load current ripple due to motor rotation speed mode changes should not exceed 2 times the steady state current during the period of the motor spin-up or spin-down.

Rationale: Bounds nominal behavior.

3.2.3.15 *Instrument Operational Transients Current Limit*

Operational transients that occur after initial turn-on should not exceed 125% of the peak operational current drawn during normal operation.

Rationale: Bounds nominal behavior.

3.2.3.16 *Instrument Reflected Ripple Current*

The peak-to-peak load current ripple generated by the Instrument should not exceed 25% of the average current on any Power Feed bus.

Rationale: Bounds nominal behavior.

3.2.4 Overcurrent Protection

3.2.4.1 *Overcurrent Protection Definition*

The analysis defining the overcurrent protection device specification(s) should consider turn-on, operational, and turn-off transients.

Rationale: Describes conditions necessary for inclusion in the “standard” design practice.

3.2.4.2 *Overcurrent Protection – Harness Compatibility*

Harness wire sizes should be consistent with overcurrent protection device sizes and derating factors.

Best Practices for Hosted Payload Interface Design Guidelines Document		
Document No: BPHPID0001	Effective 3/23/2017	Version: DRAFT
		Page 39 of 60

Rationale: Describes a “standard” design practice.

3.2.4.3 *Overcurrent Protection Device Size Documentation*

The EICD will document the type, size, and characteristics of the overcurrent protection devices.

Rationale: Describes “standard practice” EICD elements.

3.2.4.4 *Instrument Overcurrent Protection*

All Instrument overcurrent protection devices should be accessible at the Host Spacecraft integration level with minimal disassembly of the Instrument.

Rationale: Accessible overcurrent protection devices allow Systems Integrator technicians to more easily restore power to the Instrument in the event of an externally-induced overcurrent. This provides access to the overcurrent protection devices in order to both restore the integrity of the protected power circuit and to preclude the need for additional testing precipitated by Instrument disassembly.

3.2.4.5 *Instrument Fault Propagation Protection*

The Instrument and Host Spacecraft should not propagate a single fault occurring on either the “A” or “B” power interface circuit, on either side of the interface, to the redundant interface or Instrument.

Rationale: This preserves redundancy by keeping faulty power circuits from impacting alternate power sources.

3.2.4.6 *Testing of Instrument High-Voltage Power Supplies in Ambient Conditions*

Instrument high-voltage power supplies should operate nominally in ambient atmospheric conditions.

Rationale: This allows simplified verification of the high-voltage power supplies.

If the high-voltage power supplies cannot operate nominally in ambient conditions, then the Instrument design should enable a technician to manually disable the high-voltage power supplies.

Rationale: This allows verification of the Instrument by bypassing the HV power supplies that do not function in ambient conditions.

3.2.4.7 *Instrument High-Voltage Current Limiting*

The output of the high-voltage supply of each Instrument should be current limited to prevent the supply discharge from damaging the Host Spacecraft and other Instruments.

Best Practices for Hosted Payload Interface Design Guidelines Document		
Document No: BPHPID0001	Effective 3/23/2017	Version: DRAFT
		Page 40 of 60

Rationale: This prevents the power supply from damaging the Host Spacecraft or other payloads.

3.2.5 Connectors

The following best practices apply to the selection and use of all interface connectors.

3.2.5.1 *Instrument Electrical Power System Connector and Harnessing*

The Instrument electrical power system harnessing and connectors should conform to GSFC-733-HARN, IPC J-STD-001ES and NASA-STD-8739.4.

Rationale: Describes the appropriate design practices for all Instrument electrical power connections and harnessing.

3.2.5.2 *Connector Savers*

Throughout all development, integration, and test phases, connector savers should be used to preserve the mating life of component flight connectors.

Rationale: This practice serves to preserve the number of mate/de-mate cycles any particular flight connector experiences. Mate/de-mate cycles are a connector life-limiting operation. This practice also protects flight connects form damage during required connector mate/de-mate operations.

3.2.5.3 *Connector Separation*

The Instrument should physically separate the electric interfaces for each of the following functions:

- 1) +28 VDC bus power and return
- Telemetry and command signals with returns
- Deployment actuation power and return (where applicable)

Rationale: A “standard” design practice to preclude mismating and to simplify test and anomaly resolution.

3.2.5.4 *Command and Telemetry Returns*

Telemetry return and relay driver return pins should reside on the same connector(s) as the command and telemetry signals.

Rationale: A “standard” design practice to simplify testing and anomaly resolution.

3.2.5.5 *Connector Usage and Pin Assignments*

Harness side power connectors and all box/bracket-mounted connectors supplying power to other components should have female contacts.

Best Practices for Hosted Payload Interface Design Guidelines Document		
Document No: BPHPID0001	Effective 3/23/2017	Version: DRAFT
		Page 41 of 60

Rationale: Unexposed power supply connector contacts preclude arcing, mismatching, and contact shorting.

3.2.5.6 *Connector Function Separation*

Incompatible functions should be physically separated.

Rationale: A “standard” design practice to ensure connector conductor self-compatibility that precludes arcing and inductive current generation.

3.2.5.7 *Connector Derating*

Instrument and Host Spacecraft should derate electrical connectors using *Electronic Parts, Materials, and Processes for Space and Launch Vehicles (MIL-HDBK-1547A)* as a guide.

Rationale: A “standard” design practice.

3.2.5.8 *Connector Access*

At least 50 mm of clearance should exist around the outside of mated connectors.

Rationale: Ensures the ability to perform proper connector mate/de-mate operations.

3.2.5.9 *Connector Engagement*

Connectors should be mounted to ensure straight and free engagement of the contacts.

Rationale: This precludes mismatching connectors.

3.2.5.10 *Power Connector Type*

The Instrument power connectors should be space-flight qualified MIL-DTL-24308, Class M, Subminiature Rectangular connectors with standard density size 20 crimp contacts and conform to GSFC S-311-P-4/09.

Rationale: Connector sizes and types selected based upon familiarity, availability, and space flight qualification.

3.2.5.11 *Power Connector Size and Conductor Gauge*

The Instrument power connectors should be 20 AWG, 9 conductor (shell size 1) or 15 conductor (shell size 2) connectors.

Rationale: Application of stated design practices to the CII instrument power bus connectors.

3.2.5.12 *Power Connector Pin Out*

The Instrument power connectors should utilize the supply and return pin outs defined in Table 2-1 and identified in Figure 2-1 thru Figure 2-3.

Rationale: Application of stated design practices to the CII instrument power bus connectors.

Note: the connectors are depicted with the instrument side of the connector (pins) shown while the spacecraft side of the connector (sockets) is the mirror image.

Table 3-2: Instrument Power Connector Pin Out Definition

Power Bus	Circuit	Supply Conductor Position	Return Conductor Position
#1	A & B	11, 12, 13, 23, 24, 25	1, 2, 3, 14, 15, 16
#2	A & B	6, 7, 8, 13, 14, 15	1, 2, 3, 9, 10, 11
Survival Heater	A & B	4, 5, 8, 9	1, 2, 6, 7

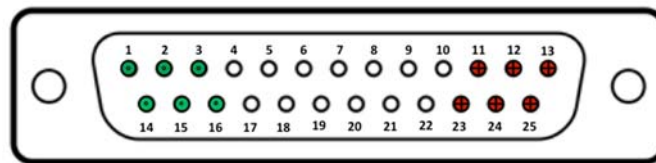

Figure 3-5: Instrument Side Power Bus #1 Circuit A & Circuit B

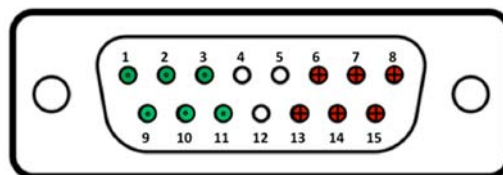

Figure 2-6: Instrument Side Power Bus #2 Circuit A & Circuit B

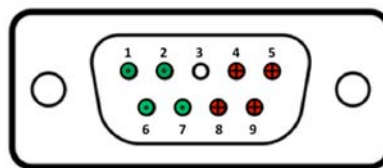

Figure 3-7: Instrument Side Survival Heater Power Bus Circuit A & Circuit B

3.2.5.13 SpaceWire Connectors and Harnessing

The Instrument SpaceWire harnessing and connectors should conform to ECSS-E-ST-50-12C.

Rationale: Describes the appropriate design practice for all SpaceWire connections and harnessing.

Best Practices for Hosted Payload Interface Design Guidelines Document		
Document No: BPHPID0001	Effective 3/23/2017	Version: DRAFT
		Page 43 of 60

3.2.5.14 Power Connector Provision

The Instrument Provider should furnish all flight-quality instrument power mating connectors (Socket Side) to the Host Spacecraft Manufacturer for interface harness fabrication.

Rationale: Assigns “standard practice” responsibility.

3.2.5.15 Power Connector Conductor Size and Type

The Instrument should have size 20 socket crimp contacts on the Instrument side power connectors and size 20 pin crimp contacts on the Host Spacecraft side power connectors.

Rationale: Application of the conductor size and type selected for the CII instrument power bus connectors to the corresponding instrument power connectors.

3.2.5.16 Power Connector Keying

The instrument power connectors should be keyed as defined in Figure 2-4.

Rationale: Application of stated design practices to the CII instrument power bus connectors.

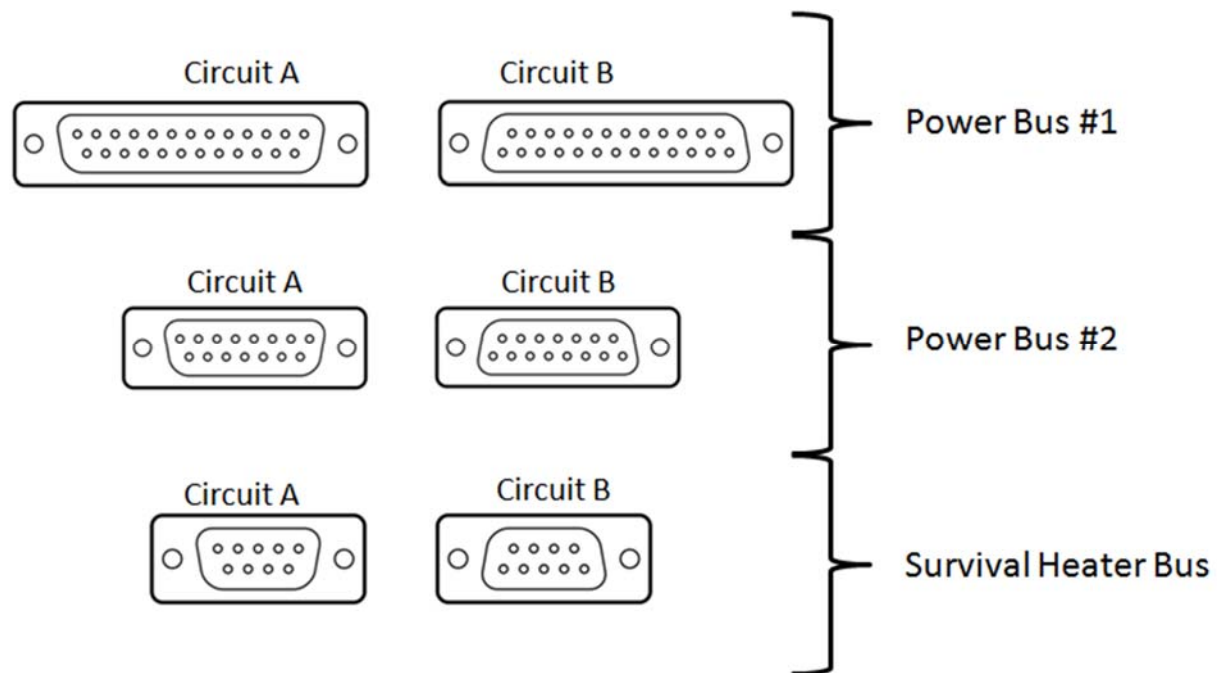

Figure 3-8: Power Connector Keying

3.2.5.17 Connector Type Selection

All connectors to be used by the Instrument should be selected from the Goddard Spaceflight Center (GSFC) Preferred Parts List (PPL).

Best Practices for Hosted Payload Interface Design Guidelines Document		
Document No: BPHPID0001	Effective 3/23/2017	Version: DRAFT
		Page 44 of 60

Rationale: Utilizing the GSFC PPL simplifies connector selection, since all of its hardware is spaceflight qualified.

3.2.5.18 *Flight Plug Installation*

Flight plugs requiring installation prior to launch should be capable of being installed at the Host Spacecraft level.

Rationale: Ensures necessary access.

3.2.5.19 *Test Connector Location and Types*

Test connector and coupler ports should be accessible without disassembly throughout integration of the Instrument and Host Spacecraft.

Rationale: This reduces the complexity and duration of integrated testing and simplifies preflight anomaly resolution.

3.3 Mechanical Interface Reference Material / Best Practices

3.3.1 Mass Centering

The Instrument center of mass should be less than 5 cm radial distance from the $Z_{instrument}$ axis, defined as the center of the Instrument mounting bolt pattern.

Rationale: Engineering analysis determined guideline Instrument mass centering parameters based on comparisons to the spacecraft envelope in the *STP-SIV Payload User's Guide*.

The Instrument center of mass should be located less than half of the Instrument height above the Instrument mounting plane.

Rationale: Engineering analysis determined guideline Instrument mass centering parameters based on comparisons to the spacecraft envelope in the *STP-SIV Payload User's Guide*.

3.3.2 Documentation of Mechanical Properties

3.3.2.1 *Envelope*

The MICD will document the Instrument component envelope (including kinematic mounts and MLI) as "not to exceed" dimensions.

Rationale: Defines the actual maximum envelope within which the instrument resides.

3.3.2.2 *Mass*

The MICD will document the mass of the Instrument, measured to less than 0.2%.

Rationale: To ensure that accurate mass data is provided for analytic purposes.

Best Practices for Hosted Payload Interface Design Guidelines Document		
Document No: BPHPID0001	Effective 3/23/2017	Version: DRAFT
		Page 45 of 60

3.3.2.3 *Center of Mass*

The MICD will document the launch and on-orbit centers of mass of each Instrument, referenced to the Instrument coordinate axes and measured to ± 1 mm.

Rationale: To ensure that accurate CG data is provided for analytic purposes.

3.3.2.4 *Moment of Inertia*

The MICD will document the moments of inertia, measured to less than 1.5%.

Rationale: To ensure that accurate moments of inertia data is provided for analytic purposes.

3.3.2.5 *Constraints on Moments of Inertia*

The MICD will document the constraints to the moments and products of inertia available to the Instrument.

Rationale: To define the inertial properties envelope within which the Instrument may operate and not adversely affect Host Spacecraft and primary instrument operations.

3.3.3 Dynamic Properties

3.3.3.1 *Documentation of Dynamic Envelope or Surfaces*

The MICD will document the initial and final configurations, as well as the swept volumes of any mechanisms that cause a change in the external envelope or external surfaces of the Instrument.

Rationale: To define variations in envelope caused by deployables.

3.3.3.2 *Documentation of Dynamic Mechanical Elements*

The MICD will document the inertia variation of the Instrument due to movable masses, expendable masses, or deployables.

Rationale: Allows Host Spacecraft Manufacturer to determine the impact of such variations on Host Spacecraft and primary payload.

3.3.3.3 *Caging During Test and Launch Site Operations*

Instrument mechanisms that require caging during test and launch site operations should cage when remotely commanded.

Rationale: To allow proper instrument operation during integration and test.

Instrument mechanisms that require uncaging during test and launch site operations should uncage when remotely commanded.

Best Practices for Hosted Payload Interface Design Guidelines Document		
Document No: BPHPID0001	Effective 3/23/2017	Version: DRAFT
		Page 46 of 60

Rationale: To allow proper instrument operation during integration and test.

Instrument mechanisms that require caging during test and launch site operations should cage when accessible locking devices are manually activated.

Rationale: To allow proper instrument operation during integration and test.

Instrument mechanisms that require uncaging during test and launch site operations should uncage when accessible unlocking devices are manually activated.

Rationale: To allow proper instrument operation during integration and test.

3.3.4 Instrument Mounting

3.3.4.1 *Documentation of Mounting*

The MICD will document the mounting interface, method, and geometry, including ground strap provisions and dimensions of the holes for mounting hardware.

Rationale: To ensure no ambiguity of mounting interface between instrument and spacecraft.

3.3.4.2 *Documentation of Instrument Mounting Location*

The MICD will document the mounting location of the Instrument on the Host Spacecraft.

Rationale: To ensure no ambiguity of mounting location on spacecraft.

3.3.4.3 *Metric Units*

The MICD will specify whether mounting fasteners will conform to SI or English unit standards.

Rationale: Metric hardware are not exclusively used industry wide. Choice of unit system likely will be set by spacecraft manufacturer.

3.3.4.4 *Documentation of Finish and Flatness Guidelines*

The MICD will document finish and flatness guidelines for the mounting surfaces.

Rationale: To ensure no ambiguity of finish and flatness requirements at instrument interface.

3.3.4.5 *Drill Template Usage*

The MICD will document the drill template details and serialization.

Rationale: Drill template details will be on record.

The Instrument Developer should drill spacecraft and test fixture interfaces using the MICD defined template.

Best Practices for Hosted Payload Interface Design Guidelines Document		
Document No: BPHPID0001	Effective 3/23/2017	Version: DRAFT
		Page 47 of 60

Rationale: A common drill template will ensure proper alignment and repeatability of mounting holes.

3.3.4.6 *Kinematic Mounts*

The Instrument Provider should provide all kinematic mounts.

Rationale: If the instrument requires kinematic mounts, they should be the responsibility of the instrument provider due to their knowledge of the instrument performance requirements.

3.3.4.7 *Fracture Critical Components of Kinematic Mounts*

Kinematic mounts should comply with all analysis, design, fabrication, and inspection requirements associated with fracture critical components as defined by NASA-STD-5019.

Rationale: Kinematic mount failure is a potential catastrophic hazard to the Instrument and the Host Spacecraft.

3.3.5 Instrument Alignment

3.3.5.1 *Documentation of Coordinate System*

The MICD will document the Instrument Reference Coordinate Frame.

Rationale: To ensure there is no ambiguity between Instrument Developer and Host Spacecraft Manufacturer regarding the Instrument Reference Coordinate System.

3.3.5.2 *Instrument Interface Alignment Cube*

If the Instrument has critical alignment requirements, the Instrument should contain an Interface Alignment Cube (IAC), an optical cube that aligns with the Instrument Reference Coordinate Frame.

Rationale: To aid in proper alignment of the Instrument to the Host Spacecraft during Integration and Test, assuming that the spacecraft provides access to its own IAC.

3.3.5.3 *Interface Alignment Cube Location*

The Instrument Developer should mount the IAC such that it is visible at all stages of integration with the Host Spacecraft from at least two orthogonal directions.

Rationale: Observation of IAC from at least two directions is required for alignment.

3.3.5.4 *Interface Alignment Cube Documentation*

The MICD will document the location of all optical alignment cubes on the Instrument.

Rationale: To have a record of the IAC locations.

Best Practices for Hosted Payload Interface Design Guidelines Document		
Document No: BPHPID0001	Effective 3/23/2017	Version: DRAFT
		Page 48 of 60

3.3.5.5 *Instrument Boresight*

The Instrument Developer should measure the alignment angles between the IAC and the Instrument boresight.

Rationale: Since this knowledge is critical to the Instrument Developer, they should be responsible for taking the measurement.

The MICD will document the alignment angles between the IAC and the Instrument boresight.

Rationale: To record the actual alignment angle in case it is needed for later analysis.

3.3.5.6 *Pointing Accuracy, Knowledge, and Stability*

The MICD will document the Host Spacecraft required pointing accuracy, knowledge, and stability capabilities in order for the Instrument to meet its operational requirements.

Rationale: To establish that Host Spacecraft pointing accuracy, knowledge and stability specifications meet requirements of instrument operation.

3.3.6 Integration and Test

3.3.6.1 *Installation/Removal*

The Instrument should be capable of being installed or removed in its launch configuration without disturbing the primary payload.

Rationale: Primary payload safety.

3.3.6.2 *Mechanical Attachment Points*

The Instrument should provide mechanical attachment points that will be used by a handling fixture during integration of the instrument.

Rationale: The handling fixtures will be attached to the Instrument while in the Integration and Test environment.

The MICD will document details of the mechanical attachment points used by the handling fixture.

Rationale: To ensure handling fixture attachment points are properly recorded.

3.3.6.3 *Load Margins*

Handling and lifting fixtures should function according to their operational specifications at five (5) times limit load for ultimate.

Best Practices for Hosted Payload Interface Design Guidelines Document		
Document No: BPHPID0001	Effective 3/23/2017	Version: DRAFT
		Page 49 of 60

Handling and lifting fixtures should function according to their operational specifications at three (3) times limit load for yield.

Handling fixtures should be tested to two (2) times working load.

Rationale: All three load margins maintain personnel and instrument safety.

3.3.6.4 *Responsibility for Providing Handling Fixtures*

The Instrument Provider should provide proof-tested handling fixtures for each component with mass in excess of 16 kg.

Rationale: This guideline protects personnel safety.

3.3.6.5 *Accessibility of Red Tag Items*

All items intended for pre-flight removal from the Instrument should be accessible without disassembly of another Instrument component.

Rationale: Instrument safety.

3.3.6.6 *Marking and Documentation of Test Points and Test Guidelines*

All test points and I&T interfaces on the Instrument should be visually distinguishable from other hardware components to an observer standing 4 feet away.

Rationale: Clear visual markings mitigate the risk that Integration and test personnel will attempt to connect test equipment improperly, leading to Instrument damage. Four feet exceeds the length of most human arms and ensures that a technician would see any markings on hardware before connecting test equipment.

The MICD will document all test points and test guidelines.

Rationale: To ensure no ambiguity of Integration and Test interfaces and test points and to aide in developing I&T procedures.

3.3.6.7 *Orientation Constraints During Test*

The MICD will document instrument mechanisms, thermal control, or any exclusions to testing and operations related to orientations.

Rationale: This documents any exceptions to the 1g functionality described in section **Error! Reference source not found.**

3.3.6.8 *Temporary Items*

All temporary items to be removed following test should be visually distinguishable from other hardware components to an observer standing 4 feet away.

Best Practices for Hosted Payload Interface Design Guidelines Document		
Document No: BPHPID0001	Effective 3/23/2017	Version: DRAFT
		Page 50 of 60

Rationale: Any preflight removable items need to be obvious to casual inspection to mitigate the risk of them causing damage or impairing spacecraft functionality during launch/operations.

The MICD will document all items to be installed prior to or removed following test and all items to be installed or removed prior to flight.

Rationale: To ensure no ambiguity of installed and/or removed items during Integration and Test through documentation.

3.3.6.9 *Temporary Sensors*

The Instrument should accommodate temporary installation of sensors and supporting hardware for use during environmental testing.

Rationale: To facilitate environmental testing.

Examples include optical simulators, acceleration sensors, and thermal monitors.

3.3.6.10 *Captive Hardware*

The Instrument Developer should utilize captive hardware for all items planned to be installed, removed, or replaced during integration, except for Instrument mounting hardware and MLI.

Rationale: Captive hardware reduces the danger to the Host Spacecraft, Instrument, and personnel from fasteners dropped during integration.

3.3.6.11 *Venting Documentation*

The MICD will document the number, location, size, vent path, and operation time of Instrument vents.

Rationale: This eliminates ambiguity regarding venting the Instrument and how it may pertain to the Host Spacecraft and primary instrument operations.

3.3.6.12 *Non-Destructive Evaluation*

Kinematic mount flight hardware should show no evidence of micro cracks when inspected using Non-Destructive Evaluation (NDE) techniques following proof loading.

Rationale: To ensure kinematic mounts meet load requirements without damage.

Best Practices for Hosted Payload Interface Design Guidelines Document		
Document No: BPHPID0001	Effective 3/23/2017	Version: DRAFT
		Page 51 of 60

3.4 Thermal Interface Reference Material / Best Practices

3.4.1 Heat Management Techniques

3.4.1.1 *Heat Transfer Hardware*

The Instrument Developer should consider implementing heat pipes and high thermal conductivity straps to transfer heat within the Instrument.

Rationale: A Host Spacecraft would likely more easily accommodate an Instrument whose thermal design is made more flexible by the inclusion of heat transfer hardware.

The payload designer should expect some amount of spacecraft backloading on the payload radiators, especially those operating at very low temperatures. The backloading on the radiators depends on the temperature of the source and the view factor between the source and the payload radiator. Solar arrays on GEO spacecraft can run as high as 100° C and any radiator in its view will have significant backloading. A radiator running 10° C can have as much as 25 W/sq m from spacecraft component at 50° C and having a 0.1 View Factor. One approach to avoid this back loading is to locate the radiator on a surface which will have least exposure to solar panels. This may require using heat pipes to transfer the waste heat to radiators.

3.4.1.2 *Survivability at Very Low Temperature*

The Instrument Developer should consider using components that can survive at -55° C to minimize the survival power demands on the Host Spacecraft.

Rationale: -55° C is a common temperature to which space components are certified. The use of components certified to this temperature decreases the survival heater power demands placed upon the Host Spacecraft.

3.4.1.3 *Implementation of Cooling Function*

The Instrument Developer should consider implementing thermoelectric coolers or mechanical coolers if cryogenic temperatures are required for the instrument to minimize the restrictions on Instrument radiator orientations.

Rationale: Thermoelectric or mechanical coolers provide an alternative technique to achieve very low temperatures that do not impose severe constraints on the placement of the radiator.

3.4.1.4 *Implementation of High Thermal Stability*

The Instrument Developer should consider implementing high thermal capacity hardware, such as phase change material, in order to increase the Instrument's thermal stability.

Rationale: Some optical instruments require very high thermal stability and given the relatively low masses expected in CII Instruments, incorporating phase change material for thermal storage is a useful technique.

Best Practices for Hosted Payload Interface Design Guidelines Document		
Document No: BPHPID0001	Effective 3/23/2017	Version: DRAFT
		Page 52 of 60

3.4.2 Survival Heaters

The use of survival heaters is a technique to autonomously apply heat to an Instrument in the event that the thermal subsystem does not perform nominally, either due to insufficient power from the Host Spacecraft or an inflight anomaly.

3.4.2.1 *Survival Heater Responsibility*

The Instrument Provider should provide and install all Instrument survival heaters.

Rationale: Survival heaters are a component of the Instrument.

3.4.2.2 *Mechanical Thermostats*

The Instrument should control Instrument survival heaters via mechanical thermostats.

Rationale: Mechanical thermostat allows control of the survival heaters while the instrument avionics are not operating.

3.4.2.3 *Survival Heater Documentation*

The TICD will document survival heater characteristics and mounting details.

Rationale: This will capture the agreements negotiated by the Host Spacecraft Manufacturer and Instrument Developer.

3.4.2.4 *Minimum Turn-On Temperatures*

The Instrument should maintain the temperature of its components at a temperature no lower than that required to safely energize and operate the components.

Rationale: Some electronics require a minimum temperature in order to safely operate.

3.4.3 Thermal Performance and Monitoring

3.4.3.1 *Surviving Arbitrary Pointing Orientations*

The Instrument should be capable of surviving arbitrary pointing orientations without permanent degradation of performance for a minimum of four (4) orbits with survival power only.

Rationale: This is a typical NASA earth orbiting science instrument survival requirement.

3.4.3.2 *Documentation of Temperature Limits*

The TICD will document temperature limits for Instrument components during ground test and on-orbit scenarios.

Rationale: This will provide values for the Integration and Test technicians to monitor and manage.

Best Practices for Hosted Payload Interface Design Guidelines Document		
Document No: BPHPID0001	Effective 3/23/2017	Version: DRAFT
		Page 53 of 60

3.4.3.3 *Documentation of Monitoring Location*

The TICD will document the location of all Instrument temperature sensors.

Rationale: This is the standard means to documents the agreement between the Host Spacecraft and Instrument.

3.4.3.4 *Temperature Monitoring During OFF Mode*

The Instrument Designer should assume that the Host Spacecraft will monitor only one temperature on the spacecraft side of the payload interface when the payload is off. During extreme cases such as host anomalies, however, even this temperature might not be available.

Rationale: This limits the demands that the Instrument may place on the Host Spacecraft.

3.4.3.5 *Thermal Control Hardware Documentation*

The TICD will document Instrument Developer-provided thermal control hardware.

Rationale: This is the standard means to documents the agreement between the Host Spacecraft and Instrument.

3.4.3.6 *Thermal Performance Verification*

The Instrument Developer should verify the Instrument thermal control system ability to maintain hardware within allowable temperature limits either empirically by thermal balance testing or by analysis for conditions that cannot be ground tested.

Rationale: These verification methods ensure that the Instrument's thermal performance meets the guidelines and agreements documented in the TICD.

3.5 **Environmental Reference Material / Best Practices**

3.5.1 Radiation-Induced SEE

The following best practices describe how the Instrument should behave in the event that a radiation-induced SEE does occur.

3.5.1.1 *Temporary Loss of Function or Loss of Data*

Temporary loss of function or loss of data is permitted, provided that the loss does not compromise Instrument or Host Spacecraft health and full performance can be recovered rapidly.

Rationale: Identifies that a temporary loss of function and/or data is permissible in support of correcting anomalous operations. This includes autonomous detection and correction of anomalous operations as well as power cycling.

Best Practices for Hosted Payload Interface Design Guidelines Document		
Document No: BPHPID0001	Effective 3/23/2017	Version: DRAFT
		Page 54 of 60

3.5.1.2 *Restoration of Normal Operation and Function*

To minimize loss of data, normal operation and function should be restored via internal correction methods without external intervention.

Rationale: Identifies that autonomous fault detection and correction should be implemented.

3.5.1.3 *Irreversible Actions*

Irreversible actions should not be permitted. The hardware design should have no parts which experience radiation induced latch-up to an effective LET of 75 MeV/mg/cm² and a fluence of 10⁷ ions/cm².

Rationale: Identifies limitations for radiation induced latch-up and prescribes both a LET and an ion fluence immunity level

3.6 **Software Engineering Reference Material / Best Practices**

The Instrument System's software should comply with Class C software development requirements and guidelines, in accordance with NPR 7150.2A

Rationale: NPR 7150.2A Appendix E assigns Class C to "flight or ground software that is necessary for the science return from a single (non-primary) instrument." NASA Class C software is any flight or ground software that contributes to mission objectives, but whose correct functioning is not essential to the accomplishment of primary mission objectives. In this context, primary mission objectives are exclusively those of the Host Spacecraft.

3.7 **Contamination Reference Material / Best Practices**

3.7.1 Assumptions

- 2) During the Instrument-to-Host Spacecraft pairing process, the Host Spacecraft Owner/Integrator and the Instrument Developer will negotiate detailed parameters regarding contamination control. The Contamination Interface Control Document (CICD) will record those parameters and decisions.

The Instrument Developer will ensure that any GSE accompanying the Instrument is cleanroom compatible in accordance with the CICD.

The Instrument Developer will ensure that any GSE accompanying the Instrument into a vacuum chamber during Host Spacecraft thermal-vacuum testing is vacuum compatible in accordance with the CICD.

The Host Spacecraft Manufacturer/Systems Integrator will attach the Instrument to the Host Spacecraft such that the contamination products from the vents of the Instrument do not directly impinge on the contamination-sensitive surfaces nor directly enter the aperture of another component of the Host Spacecraft system.

Best Practices for Hosted Payload Interface Design Guidelines Document		
Document No: BPHPID0001	Effective 3/23/2017	Version: DRAFT
		Page 55 of 60

The Host Spacecraft Manufacturer/Systems Integrator will install protective measures as provided by the Instrument Provider to protect sensitive Instrument surfaces while in the Shipment, Integration and Test, and Launch environments.

The Launch Vehicle Provider will define the upper limit for the induced contamination environment. This is typically defined as the total amount of molecular and particulate contamination deposited on exposed spacecraft surfaces from the start of payload fairing encapsulation until the upper stage separation and contamination collision avoidance maneuver (CCAM).

3.7.2 Instrument Generated Contamination

3.7.2.1 *Verification of Cleanliness*

The Instrument Developer should verify by test the cleanliness of the instrument exterior surfaces documented in the CICD, prior to delivery to the Host Spacecraft Manufacturer/Systems Integrator.

Rationale: The Instrument must meet surface cleanliness requirements that are consistent with the cleanliness requirements as specified for the Host Spacecraft by the Spacecraft Manufacturer. A record of the cleanliness verification should be provided to the Host Spacecraft Manufacturer prior to Instrument integration with the Host Spacecraft.

3.7.2.2 *Instrument Sources of Contamination*

The CICD will document all sources of contamination that can be emitted from the Instrument.

Rationale: This determines the compatibility of the Instrument with the Host Spacecraft and mitigates the risk of Instrument-to-Host-Spacecraft cross contamination.

3.7.2.3 *Instrument Venting Documentation*

The CICD will document the number, location, size, vent path, and operation time of all Instrument vents.

Rationale: Mitigation of Instrument-to-Host-Spacecraft cross contamination (See 2.7.2.2)

3.7.2.4 *Flux of outgassing products*

The CICD will document the flux (g/cm²/s) of outgassing products issuing from the primary Instrument vent(s).

Rationale: Mitigation of Instrument-to-Host-Spacecraft cross contamination (See 2.7.2.2)

3.7.2.5 *Sealed Hardware*

The Instrument should prevent the escape of actuating materials from Electro-explosive devices (EEDs), hot-wax switches, and other similar devices.

Best Practices for Hosted Payload Interface Design Guidelines Document		
Document No: BPHPID0001	Effective 3/23/2017	Version: DRAFT
		Page 56 of 60

Rationale: Mitigation of Instrument-to-Host-Spacecraft cross contamination (See 2.7.2.2)

3.7.2.6 *Nonmetallic Materials Selection*

The Instrument design should incorporate only those non-metallic materials that meet the nominal criteria for thermal-vacuum stability: Total Mass Loss (TML) \leq 1.0 %, Collected Volatile Condensable Material (CVC) \leq 0.1 %, per ASTM E595 test method.

Rationale: Host Spacecraft Manufacturers generally require that all nonmetallic materials conform to the nominal criteria for thermal-vacuum stability. A publicly accessible database of materials tested per ASTM E595 is available at: <https://outgassing.nasa.gov> Note: Some Host Spacecraft Manufacturers may require lower than the nominal levels of TML and CVC.

3.7.2.7 *Wiring and MLI Cleanliness Guidelines*

The CCID will document thermal vacuum bakeout requirements for Instrument wiring harnesses and MIL.

Rationale: Thermal vacuum conditioning of materials and components may be necessary to meet Host Spacecraft contamination requirements.

3.7.2.8 *Particulate Debris Generation*

The Instrument design should avoid the use of materials that are prone to produce particulate debris.

Rationale: Host Spacecraft Manufacturers generally prohibit materials that are prone to produce particulate debris, either from incidental contact or through friction or wear during operation. Therefore, such materials, either in the construction of the payload or ground support equipment, should be avoided. Where no suitable alternative material is available, an agreement with the Host Spacecraft will be necessary and a plan to mitigate the risk posed by the particulate matter implemented.

3.7.2.9 *Spacecraft Integration Environments*

The Instrument should be compatible with processing in environments ranging from IEST-STD-1246 ISO-6 to ISO-8.

Rationale: Host Spacecraft integration facilities may vary in cleanliness and environmental control capabilities depending on the Host Spacecraft Manufacturer and integration/test venue. Instruments and associated ground support equipment should be compatible with protocols contamination control of ISO-6 cleanroom environments. Instruments should be compatible with operations in up to ISO-8 environments, employing localized controls such as bags, covers, and purges to preserve cleanliness; such controls must be integrated into the Host Spacecraft integrations process.

Best Practices for Hosted Payload Interface Design Guidelines Document		
Document No: BPHPID0001	Effective 3/23/2017	Version: DRAFT
		Page 57 of 60

3.7.3 Accommodation of Externally Generated Contamination

3.7.3.1 *Protective Covers: Responsibility*

The Instrument Developer should provide protective covers for any contamination-sensitive components of the Instrument.

Rationale: Preservation of Instrument cleanliness during Host Spacecraft I&T.

3.7.3.2 *Protective Covers: Documentation*

The CICD will document the requirements and procedures for the use of protective covers (such as bags, draping materials, or hardcovers).

Rationale: Preservation of Instrument cleanliness during Host Spacecraft I&T.

3.7.3.3 *Instrument Cleanliness Requirements*

The CICD will document the cleanliness goals for all contamination-sensitive instrument surfaces that will be exposed while in the Integration and Test Environment.

Rationale: Enables the Spacecraft Manufacturer and Instrument Provider to negotiate appropriate and reasonable instrument accommodations or determine the degree of deviation from the defined goals.

3.7.4 Instrument Purge Requirements

The CICD will document Instrument purge requirements, including type of purge gas, flow rate, gas purity specifications, filter pore size, type of desiccant (if any), and whether interruptions in the purge are tolerable.

Rationale: The Host Spacecraft Manufacturer generally will provide access to a gas supply of the desired type, purity, and flow rate. The Instrument provider is responsible to provide the necessary purge interface ground support equipment (See 2.7.4.1).

3.7.4.1 *Instrument Purge Ground Support Equipment (GSE)*

The Instrument Provider should provide purge ground support equipment (GSE) incorporating all necessary filtration, gas conditioning, and pressure regulation capabilities.

Rationale: The Instrument provider is responsible for control of the gas input to the instrument during Host Spacecraft Integration & Test. This purge GSE is the interface between the Instrument and the gas supply provided by the Spacecraft Manufacturer.

3.7.4.2 *Spacecraft to Instrument Purge Interface*

The MICD will document any required mechanical interface of the Instrument purge between the Instrument and Host Spacecraft.

Best Practices for Hosted Payload Interface Design Guidelines Document		
Document No: BPHPID0001	Effective 3/23/2017	Version: DRAFT
		Page 58 of 60

Rationale: The MICD is used to document agreements concerning the mechanical interface. The Host Spacecraft Manufacturer will negotiate with the Launch Vehicle Provider any resultant required purge interface between the Host Spacecraft and Launch Vehicle.

3.7.4.3 *Instrument Inspection and Cleaning During I&T: Responsibility*

The Instrument Provider should be responsible for cleaning the Instrument while in the Integration and Test Environment.

Rationale: The Instrument Provider is responsible for completing any required inspections during I&T. The Instrument Provider may, upon mutual agreement, designate a member of the Host Spacecraft I&T team to perform inspections and cleaning.

3.7.4.4 *Instrument Inspection and Cleaning During I&T: Documentation*

The CICD will document any required inspection or cleaning of the Instrument while in the Integration and Test Environment.

Rationale: Instrument inspections and cleaning consume schedule resources and must be conducted in coordination with other Spacecraft I&T activities.

3.7.4.5 *Spacecraft Contractor Supplied Analysis Inputs*

The CICD will document the expected Host Spacecraft-induced contamination environment.

Rationale: Mitigate the risk of Instrument-Host Spacecraft cross contamination. The Host Spacecraft Manufacturer may perform analyses or make estimates of the expected spacecraft-induced contamination environment, which will be documented in CICD. The results of such assessments may include a quantitative estimate of the deposition of plume constituents to Instrument surfaces and be used to determine the allowable level of contamination emitted from the Instrument.

3.7.4.6 *Launch Vehicle Contractor Supplied Analysis Inputs*

The CICD will document the Launch Vehicle-induced contamination environment

Rationale: Most Launch Vehicle Providers are able to provide nominal information regarding the upper bound of molecular and particulate contamination imparted to the Spacecraft Payload surfaces; frequently such information is found in published User Guides for specific Launch Vehicles. Host Spacecraft Manufacturers and Instrument Developers should use this information in developing mitigations against the risk of contamination during integrated operations with the Launch Vehicle.

Best Practices for Hosted Payload Interface Design Guidelines Document		
Document No: BPHPID0001	Effective 3/23/2017	Version: DRAFT
		Page 59 of 60

3.8 Model Guidelines and Submittal Details

3.8.1 Finite Element Model Submittal

The Instrument Developer should supply the Host Spacecraft Manufacturer with a Finite Element Model in accordance with the GSFC GIRD.

Rationale: The GIRD defines a NASA Goddard-approved interface between the Earth Observing System Common Spacecraft and Instruments, including requirements for finite element models. As of the publication of this guideline document, Gird Rev B is current, and the Finite Element Model information is in Section 11.1.

3.8.2 Thermal Math Model

The Instrument Developer should supply the Host Spacecraft Manufacturer with a reduced node geometric and thermal math model in compliance with the following sections.

Rationale: The requirements and details for the Thermal Model submittal listed in this section are based on commonly used NASA documents such as GSFC GIRD and JPL spacecraft instrument interface requirement documents.

3.8.2.1 *Model Format*

Model format should be in Thermal Desktop version 5.2 or later or NX Space Systems Thermal version 7.x or later.

3.8.2.2 *Units of Measure*

The MICD will specify model units of measure.

3.8.2.3 *Radiating Surface Element Limit*

Radiating surface elements should be limited to less than 200.

3.8.2.4 *Thermal Node Limit*

Thermal nodes should be limited to less than 500.

3.8.2.5 *Model Verification*

The Geometric Math Model and Thermal Math Model should be documented with a benchmark case in which the Host Spacecraft Manufacturer may use to verify the model run.

3.8.2.6 *Steady-State and Transient Analysis*

The model should be capable of steady-state and transient analysis.

3.8.2.7 *Reduced Node Thermal Model Documentation*

The Instrument Provider should supply the Spacecraft Developer with documentation describing the reduced node thermal model. The documentation should contain the following:

Best Practices for Hosted Payload Interface Design Guidelines Document		
Document No: BPHPID0001	Effective 3/23/2017	Version: DRAFT
		Page 60 of 60

3) Node(s) Location: the node(s) location at which each temperature limit applies.

Electrical Heat Dissipation: a listing of electrical heat dissipation and the node(s) where applied.

Active Thermal Control: a listing of active thermal control, type of control (*e.g.*, proportional heater), and the node(s) where applied.

Boundary Notes: a listing and description of any boundary nodes used in the model.

Environmental Heating: a description of the environmental heating (Beta angle, heliocentric distance, planetary albedo, planetary emissive power, *etc.*).

User Generated Logic: a description of any user generated software logic

3.8.3 Thermal Analytical Models

The Instrument Provider should furnish the Spacecraft Manufacturer with a written report documenting the results of the detailed thermal analysis and the comparison of results to the reduced node model, including a high-level energy balance and heat flow map.

3.8.4 Mechanical CAD Model

3.8.4.1 *Model Format*

The Instrument Provider should provide Mechanical CAD models in a file format compatible with the Host Spacecraft Manufacturer-specified CAD applications or in a neutral file format, such as IGES or STEP.

Rationale: The Host Spacecraft Manufacturer may need Mechanical CAD models for hosted payload assessment studies.

3.8.5 Mass Model

3.8.5.1 *Instrument Mass Model*

The Instrument Provider should provide all physical mass models required for spacecraft mechanical testing.

Rationale: The Host Spacecraft Manufacturer may fly the mass model in lieu of the Instrument in the event that Instrument delivery is delayed.