



Jet Propulsion Laboratory
California Institute of Technology

Roman Coronagraph Instrument (CGI) “Lessons” for the Future

Dr. Feng Zhao, Deputy Manager

On behalf of

Roman Space Telescope –
Coronagraph Instrument (CGI)

Nov 1, 2023

• NASA GODDARD SPACE FLIGHT CENTER • JET PROPULSION LABORATORY •
• L3HARRIS TECHNOLOGIES • BALL AEROSPACE • TELEDYNE • NASA KENNEDY SPACE CENTER •
• SPACE TELESCOPE SCIENCE INSTITUTE • INFRARED PROCESSING AND ANALYSIS CENTER •
• EUROPEAN SPACE AGENCY • JAPAN AEROSPACE EXPLORATION AGENCY •
• CENTRE NATIONAL d'ÉTUDES SPATIALES • MAX PLANCK INSTITUTE FOR ASTRONOMY •

Copyright 2023 California Institute of Technology.
Government sponsorship acknowledged

LRR076406

- Background
- Roman CGI experience and recommendations to future coronagraph instruments/projects
 1. Spectroscopy
 2. HOWFS GITL (High-order wavefront sensing, Ground-in-the-loop)
 3. Coronagraph Masks/architecture
 4. Deformable Mirror (DM)
 5. Coronagraph Software System
 6. DM Electronics
 7. Modeling
 8. Photon-counting detector
- Q&A

- **Some history**

- 2010: Astro2010 recommended WFIRST as wide field near-IR mission with 5-year prime mission;
- 2013: NASA added Coronagraph instrument (CGI) as technology demonstration but treated as science instrument, increased prime mission to 6 years;
- 2016: Mid-Decadal endorsed the addition of CGI to WFIRST, calling for CGI science;
- 2017: WIETR descope CGI to technology demonstration only, decreased prime mission to 5 years; 3 months reserved for Coronagraph instrument observations within first 18 months;
- 2019: CGI descope IFS, replace with Prism; (pre-PDR);
- 2020: NASA directed Coronagraph Instrument team to focus only on threshold (TTR5*) requirements but retain PDR design, change to class D, CGI has its own cost cap; (KDP-C);
 - Following SRB and CGI tiger team recommendations
- 2021: Community contributed additional coronagraph masks/occulters to fill in available PAM slots.

- *TTR5: Roman shall be able to measure brightness of an astrophysical point source w/ $\text{SNR} \geq 5$ located $6 - 9 \lambda/D$ from an adjacent star with $V_{AB} \leq 5$, flux ratio $\geq 10^{-7}$; bandpass shall have a central wavelength ≤ 600 nm and a bandwidth $\geq 10\%$.

Roman Program-Level Requirements Appendix (PLRA): Programmatic Requirements

- The CGI shall not delay the **launch date**, **adversely impact** the achievement of full mission success, or **increase** the overall **risk posture** of the primary mission.
- Aside from providing the CGI with reasonable and limited required interfaces (optical, mechanical, electrical, thermal, data, etc.), the Observatory shall not be required to provide enhanced capabilities beyond those required for WFIRST in the absence of a coronagraph.
- Authority to allocate Observatory schedule to [the core survey] investigations, to the coronagraph technology demonstration, and to the General Observer program, is held by the *Roman* Project Scientist.
- The design lifetime for the CGI shall be 18 months beyond In Orbit Commissioning (IOC).

Roman Experience:

- Not having enough resource margins (volume, mass, power, etc.) early (MCR), resulting in later painful IFS (Integral field spectrograph) descope (replaced with Prism) at PDR
 - IFS vs. Slit/Prism performance, SNR, etc. considered, but not the driver for the descope

Recommendation to Future:

- Conduct early trade on spectroscopy approach (IFS, Prism, etc.)
- New technology instruments shall have extra engineering margins beyond current Flight Project Practices (or GOLD Rules) requirement at MCR/MDR to accommodate additional uncertainties from multiple new technologies.

Roman Experience:

- IFS prototype (PISCES) could not repeat high contrast demonstration after initial un-common path WFE calibration drifted.

Recommendation to Future:

- Future IFS shall consider having build-in wavefront sensing capabilities to $\sim <10\text{nm}$ rms prior to “dark hole digging” using EFC (Electric Field Conjugate).

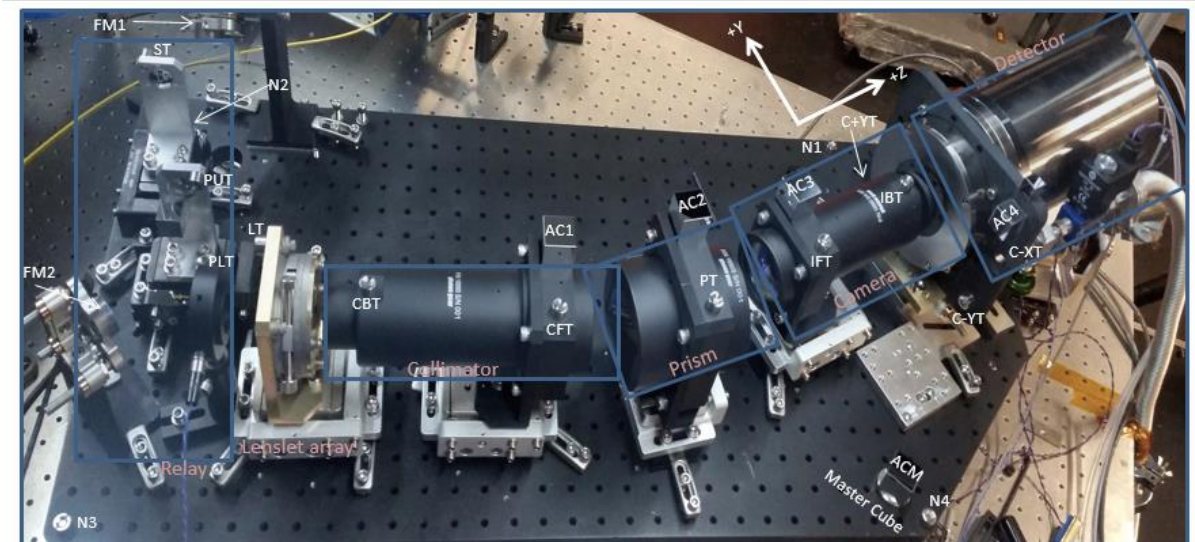

PISCES (Prototype Imaging Spectrograph for Coronagraphic Exoplanet Studies)

Roman Experience:

- During formulation and preliminary design phases, programmatically mandated inability to move functionality/computations to the ground over-complicated flight segment requirements and design, until post-CDR Tiger Team removed that constraint and HOWFSC computations were moved to the ground.
- GITL enables Roman coronagraph performance not negatively impacted by existing (small) flight computers

Recommendation to Future:

- Consider having ground-in-the-loop (GITL) for HOWFS
 - Reduce new technology risks in both Flight Computer and HOWFS algorithms/FSW
 - Enables infusion of future new algorithms, new capabilities due to rapid advancement in AI, ML, etc.

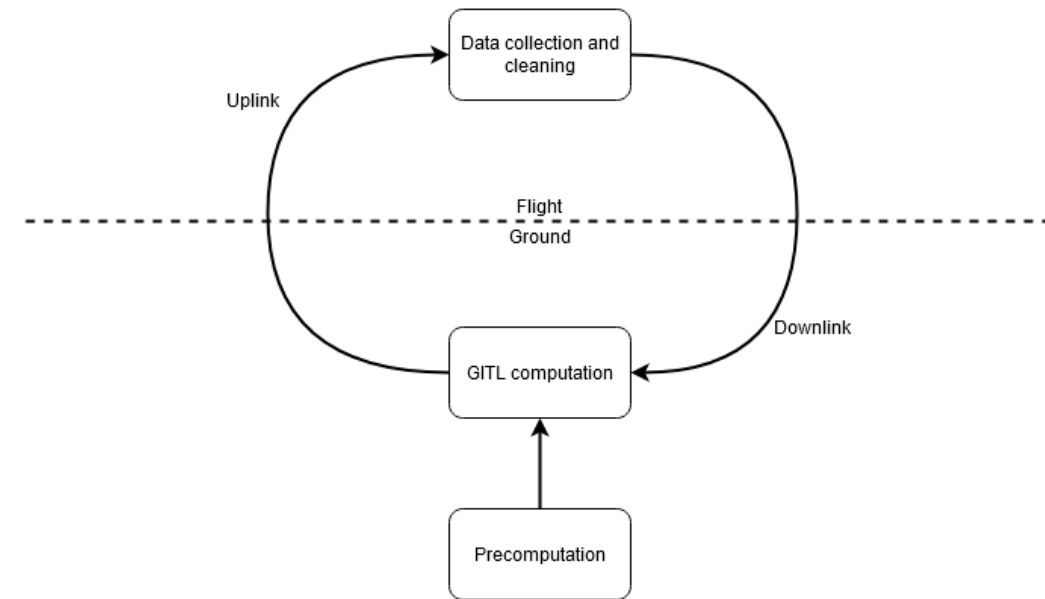
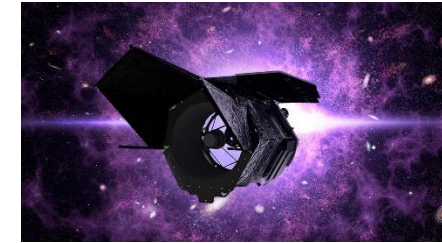

Lessons #3: Coronagraph Masks/Architecture



Roman CGI Experience:

- Engineering errors (e.g., mask fab error, alignment error) degrade coronagraph performance

Recommendation to Future:

- Apply engineering tolerances to each mask design, include mask fab error, alignment error, etc., to performance budget.

Roman CGI Experience:

- Prioritize on one type of mask/occulter for tech maturation to satisfy gate reviews (PDR, CDR)
- Extra PAM (Precision Alignment Mechanism) slots enable late community contribution of additional masks/occulters without jeopardizing the project at gate reviews

Recommendation to Future:

- Adopt a coronagraph architecture that can accommodate multiple coronagraph mask configurations.
- Allow later infusion of technology breakthroughs.

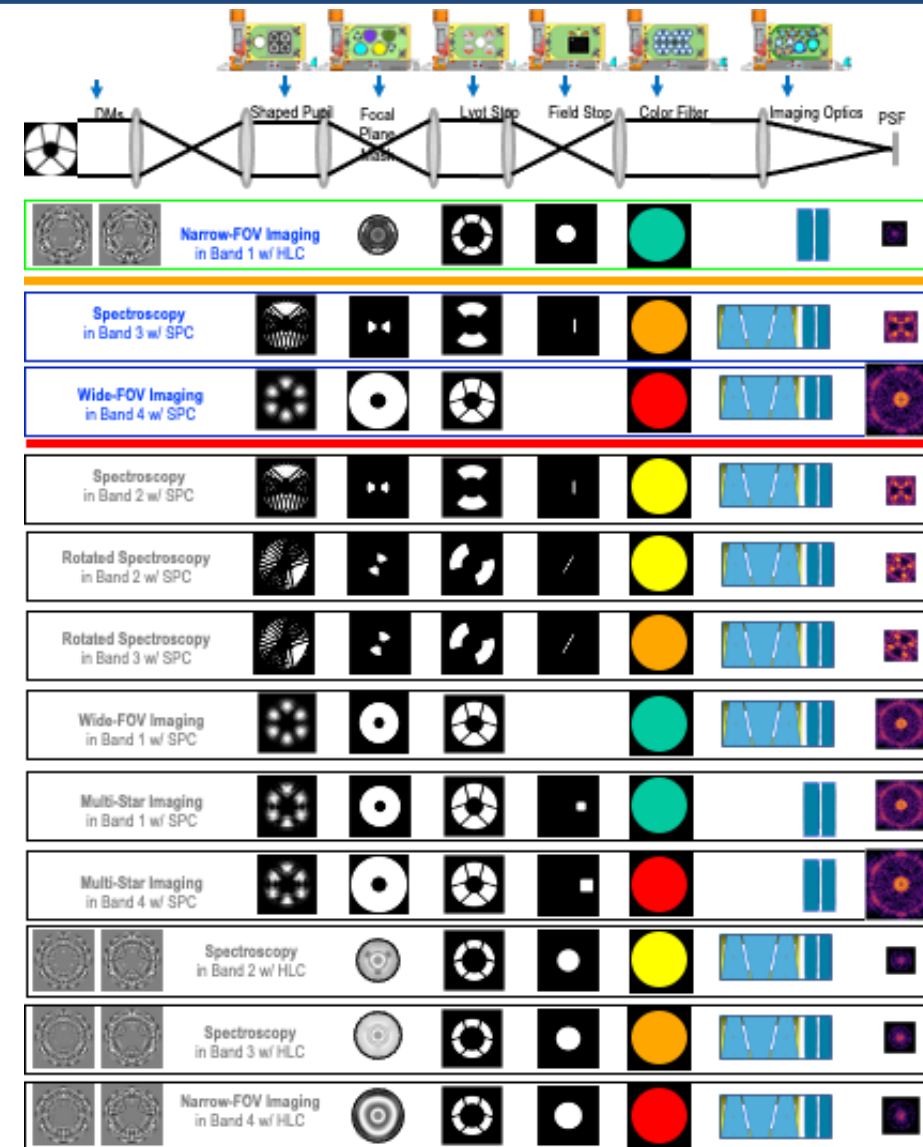

Contributed masks

Roman Experience:

- DMs are critical technology items with significant technical and schedule risks, flight as-built DMs have some requirement deviations
- CGI made a number of accommodations to deal with as-built flight DMs:
 - *Dead actuator and smaller total stroke:* → accommodated by modifying HOWFS algorithms (Jacobian update)
 - *Cross-talk:* → accommodated by careful calibration of cross-talk levels and incorporate into HOWFS algorithms
 - *larger DM static surface error (Z6):* → accommodated by compensation with rest of the beam train (readjusting OAPs in CGI). A back up option is a static fold mirror compensator (by Optimax)
 - *Longer actuator settling time:* → accommodated by Con-ops (settle during WFI observation)
 - *Actuator creep:* → accommodated by Con-ops (chopping between REF and TARGET stars)

Recommendation to Future:

- Reserve engineering resources and con-ops to accommodate as-built DMs with requirement deviations.
- Fund 2 types of DMs in parallel, make flight optical bench to accommodate either type, and select the ones that meet technical/schedule requirements.

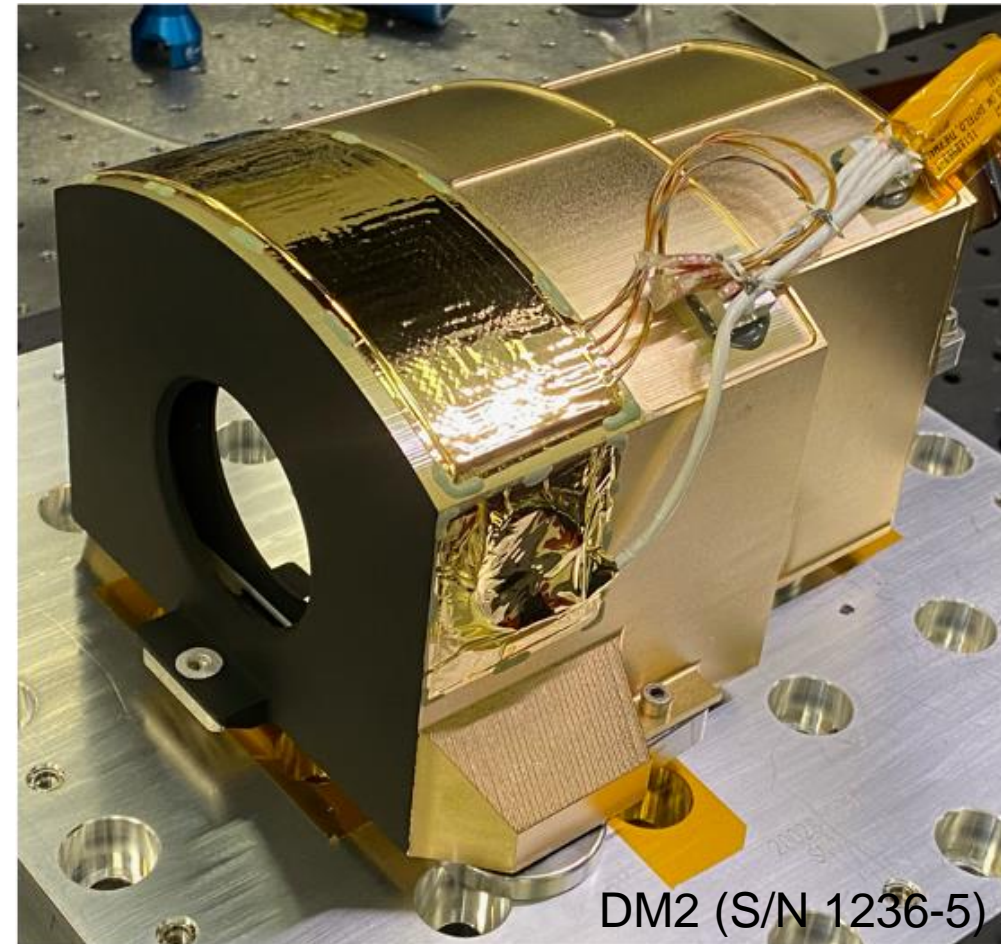

Xinetics DM:

48X48 actuators, 1mm actuator spacing, ~ 50mm dia, unprotected Al coating

Roman CGI Experience:

- Coronagraph is highly inter-active at systems level, with multiple functional layers (infrastructure layer, device layer, behavioral layer, operational layer.....)
- ~200,000 SLOC (source lines of code)

Recommendation to Future:

- Software architecture should be a high priority in HWO System level design and trade studies
- Build full instrument engineering model, not just at the sub-element level, so we can run the flight-like software to address system level functions and behaviors.

CGI "Controls Diagram"

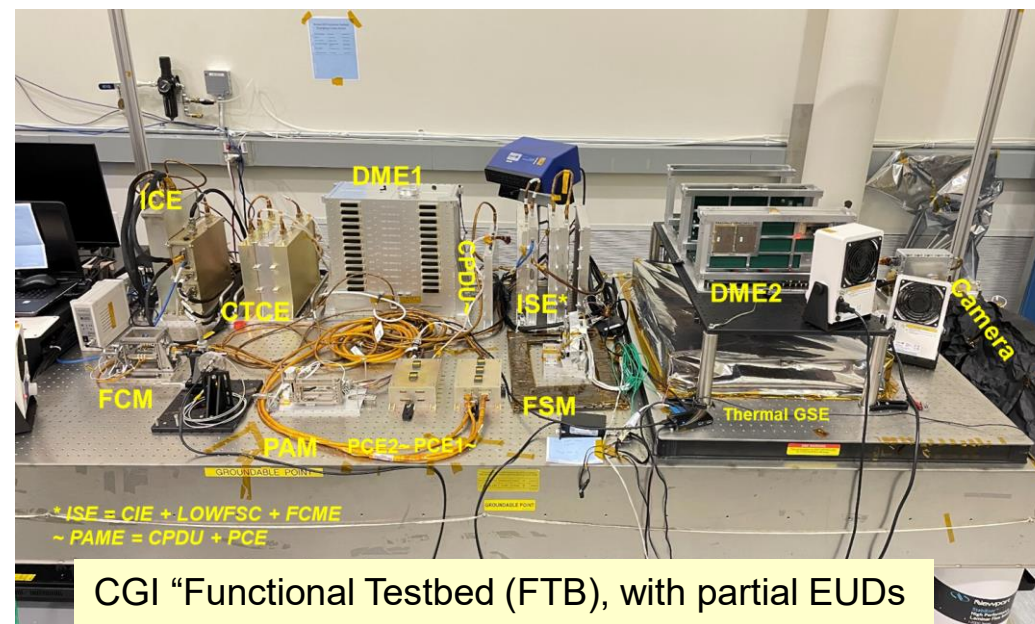
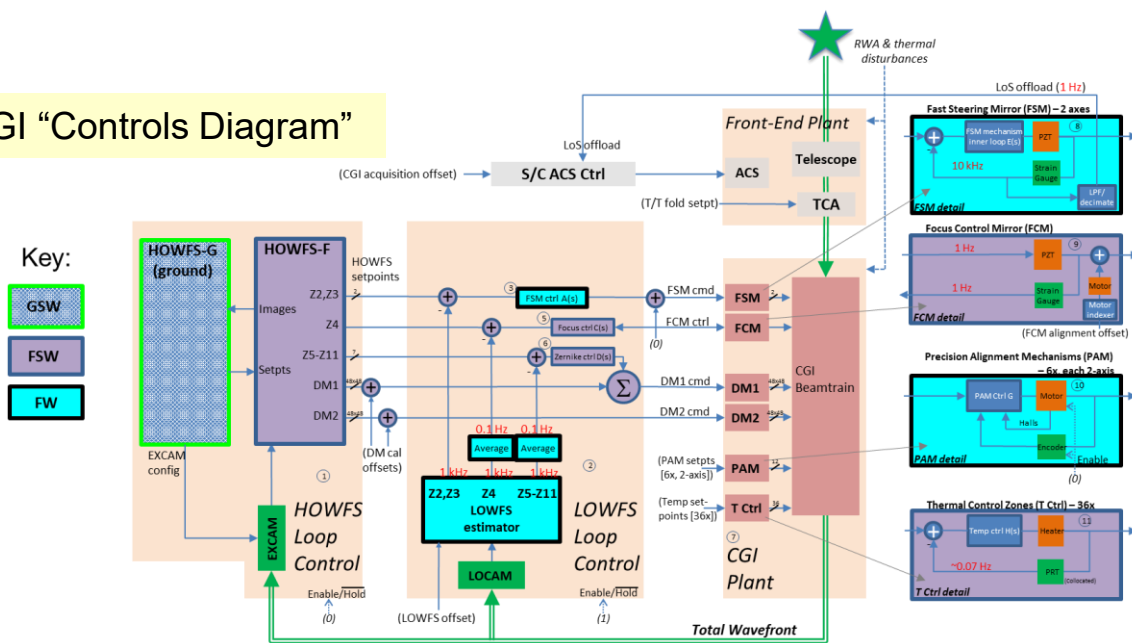

CGI "Functional Testbed (FTB), with partial EUDs

Roman CGI Experience:

- DM Electronics design uses discrete parts to drive 1649 programmable channels (0 – 100V, 16-bit DAC) for each DM.
- Each DME unit has 16 slices, heavy (~27kg/ea), high power consumption (~53W/ea), long I&T schedule (parts screening, testing, etc.)

Recommendation to Future:

- Consider invest in high packaging density and high reliability ASICs for larger format DMs (96X96) under GOMAP.

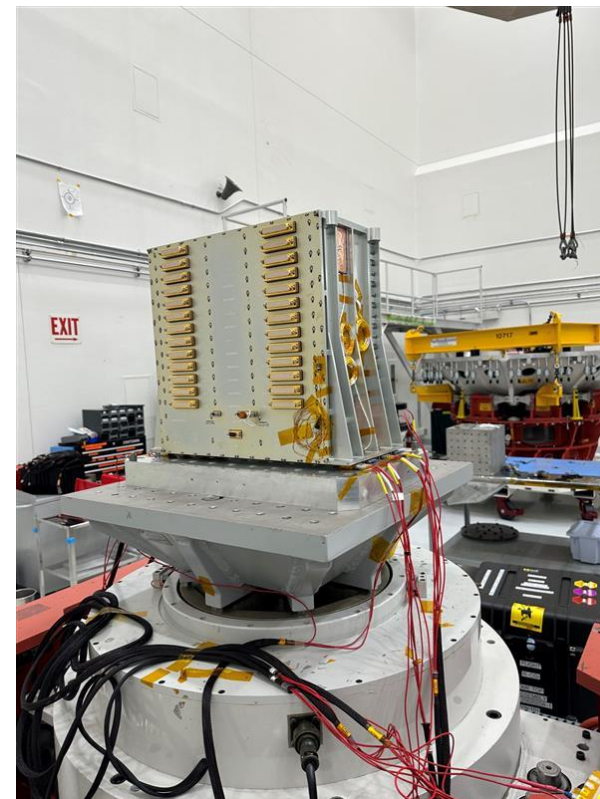

13 driver cards for each DME

- **EEE Parts** → If high reliability automotive COTS EEE parts with proper screening and qualifications have shown acceptable performance and reliability for ETU, stay with the same COTS parts for flight even if flight equivalent parts exist
 - CGI project lost six months schedule as a result of replacing >14,000 bad resistors in Deformable Mirror Electronics
- **Performance models** → invest in Physics-based performance & control models, validations in testbeds. System level performance models are extremely important in timely assessing designs, as-built flight components and assemblies to protect schedule and preserve performance.
- **Photon-counting detector** → Invest in early technology studies and trades, including associated electronics and firmware/software functions. Define operational requirements to detectors based on science cases. Project to test detectors at the project using flight-like electronics/firmware/software, or “GFE” to vendor.

COTS = Commercial off-the-shelf

ETU = Engineering Test Unit

GFE = Government Furnished Equipment