



System Engineering and the Road to Mission Concept Review (MCR)

October 31, 2023

Mike Menzel

JWST Mission Systems Engineering



Purpose and Topics

- **Presentation Purpose:** To describe the basic NASA Systems Engineering Process as called out in NPR 7123.1 and GPR 7123.1 and to describe the road to the first critical milestone of that process, the Mission Concept Review.

- **Topics**
 - Systems Engineering Primer
 - Basic Functions: Requirements Analyses, System Design, Systems Analysis, Risk Management, Validation / Verification
 - Systems Engineering Organization
 - NASA Project Life Cycle
 - Development Phases and Reviews
 - Mission Concept Review
 - MCR Purpose and Criteria
 - Road to MCR
 - Summary



What Does a Systems Engineer Do?

Science Objective:

- Detect and Investigate the First Light Sources
- “Study the Assembly of Galaxies Since First Light “



Formulate Mission Requirements

- Sensitivity
- Image Quality and Resolution
- Field Of View
- Data Throughput
- Observing Efficiency

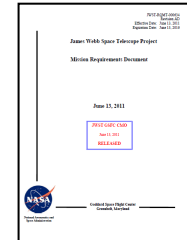

Design the System

James Webb Space Telescope System

Launch Segment



Observatory Segment



Ground Segment

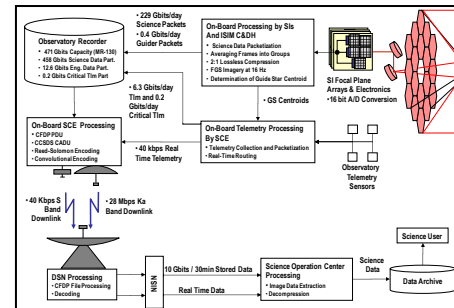
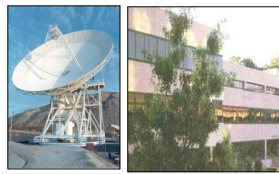

WFE Budget

Power Budget

Mass Budget

Systems Analyses and Performance Assessments

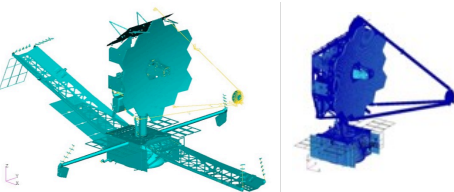

Risk Management and Technology Development

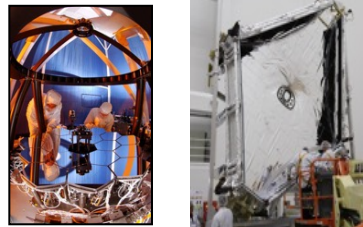

Verification of the “As Built” System

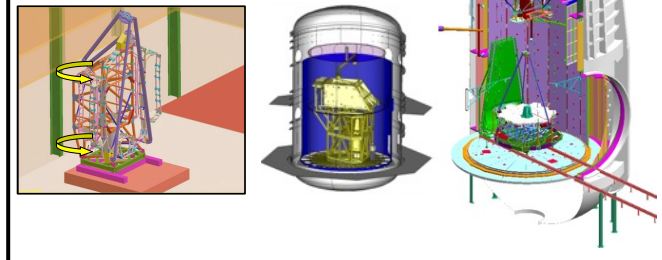



Requirements Analysis

- **Requirements Types:**
 - Functional (What does the system need to do; Functional Analysis)
 - Performance (How well does it need to do it; budgets)
 - Interface Requirements (Inputs / Outputs, Constraints)
 - Environmental Requirements (What does the system have to survive or operate in)
- **Many requirements are time specific.**
 - Mission Phases have to be considered / defined.
- **There are rules and “etiquette” for generating good requirements.**
 - Requirements will eventually form the basis of contracts.
 - MIL-STD-590 describes how to write and document requirements
- **System level requirements will be decomposed into “child requirements” and allocated to the various parts of the system.**
 - This flow-down is the trail of breadcrumbs for the verification of the system elements, and eventually the verification of the system.

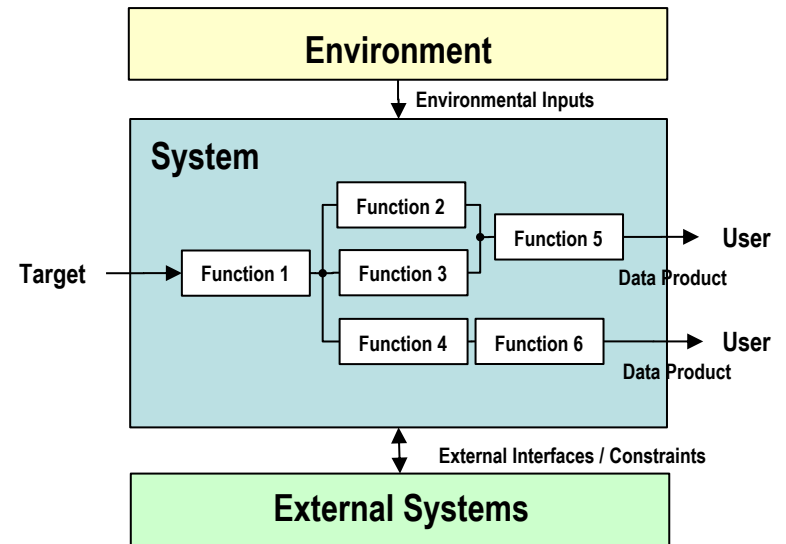

Mission Phases (Specific Time Periods)

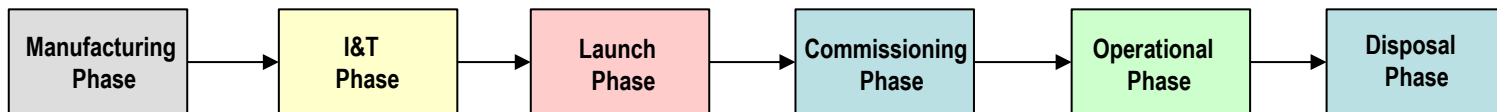

- **Environments** (Facility, Transport)
- **External Interfaces**
- **Modes:** (Usually characterized by a specific root function)
 - Special Test Modes
 - Contingency Modes
- **System States and or Configurations:** (Stowed, Deployed, Partially Assembled)



Systems Design

- **System Design is NOT detailed design but rather a definition of the child requirements, internal interfaces and constraints needed for detailed product designers to design their items.**
- **Typical system design:**
 - Identify and specify Launcher / Ground Segment / Observatory / Trajectory
 - Payload Sizing / Definition: Telescope Aperture / Science Compliment
 - Data Flow and Processing
- **Most systems are NOT linear, and the sum of optimized parts does not usually mean the system is optimized.**
 - Trades are usually not nearly as “decoupled” as folks want.
 - Trades need to be closed with options that optimize the system.
- **System Design is usually iterative. First couple of iterations are usually intended to prove that a system solution is possible / affordable.**
 - An Existence Proof
 - A reasonably good point of departure for more detailed trades
- **Baseline control of a system is important during these trades.**
 - The baseline may not be optimal or compliant with requirements, but it should be self consistent. (Budgets / performance predictions / schematics / interfaces / data flows all consistent.)

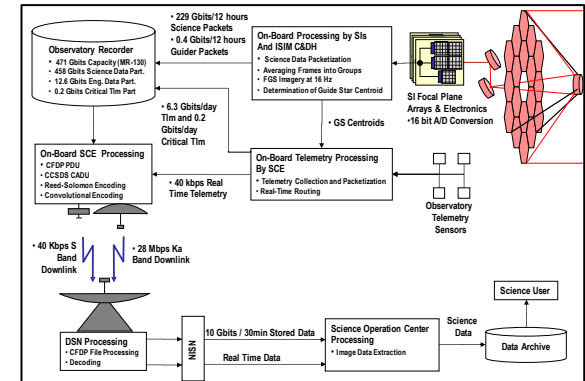
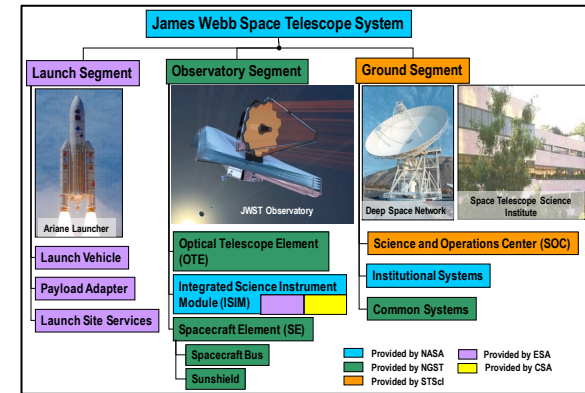

Subsystem Rating	Subsystems				
	Attitude Control	Propulsion	Thermal	Flight Software	Operations
Best	Option 1	Option 1	Option 1	Option 1	Option 1
	Option 2	Option 2	Option 2	Option 2	Option 2
	Option 3		Option 3	Option 3	
Worst			Option 4	Option 4	
			Option 5		
Option Combination Best for the System					

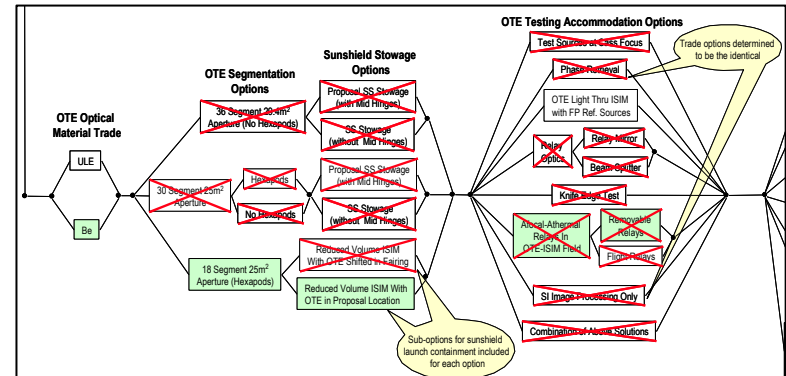



Systems Analysis

- **Systems Technical Performance Metrics (TPMs) are tracked to make sure the system is developing to meet its requirements.**
 - Select parameters to show the health of the system.
- **Systems level “Integrated Modeling” is performed to compute many of the more involved TPMs.**
 - Optical, CAD, Structural, Thermal and Control models from the individual elements or subsystems are integrated into a systems model.
 - Model interfaces and quality / consistency checks need to be specified.
- **Integrated Models are run in cycles which have specific purposes during different phases of development.**
 - Early runs are usually for problem identification. (Reconnaissance).
 - Subsequent runs support system level trades.
 - Later runs prove system compliance to requirements and verification of the “As Built” Systems.
 - Models will need to be validated and or correlated to actual hardware test results.
 - Independent model cross checks need to established.
 - **NOTE: Systems Modeling Does Not Prove Workmanship!**
- **Modeling must identify and quantify its inherent inaccuracies and or system sensitivities to establish necessary margin levels.**
 - Established by runs of the model to various parameter variations.
- **Fidelity of the models to the “To Be Built” or “As Built” system must be rigorously tracked and managed.**
 - A system of Threats and Liens lists should be established to track differences.
- **TPM margins should consider the Threats, Liens and Prediction Uncertainty.**

TPM	Status
Sensitivity	Acceptable margins
Efficiency	Acceptable margins
Data Volume / Link	Acceptable margins
Momentum	Requires improvement & improvement is likely
Commissioning Time	Requires improvement & improvement is likely
Strehl, EE, OTE WFE	Acceptable margins
WFE Stability	Acceptable margins
Image Motion	Requires improvement & improvement is likely
Stray Light Levels	Requires improvement & improvement is likely
Cryogenic Thermal Margins	Acceptable margins
Mass Margin	Requires improvement & improvement is likely
Power Margin	Acceptable margins

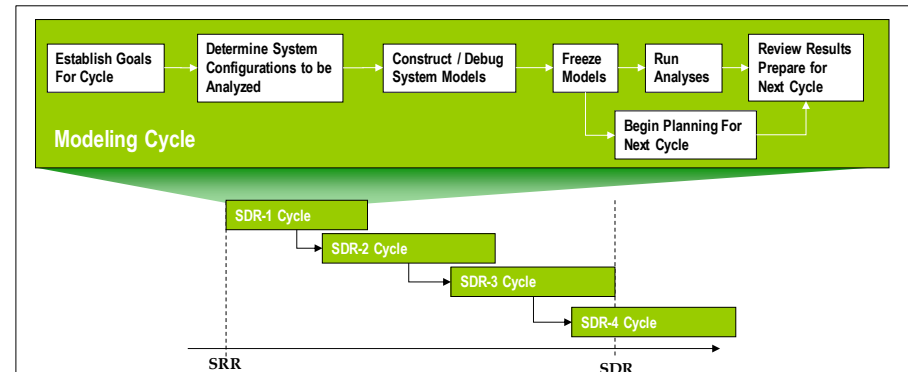
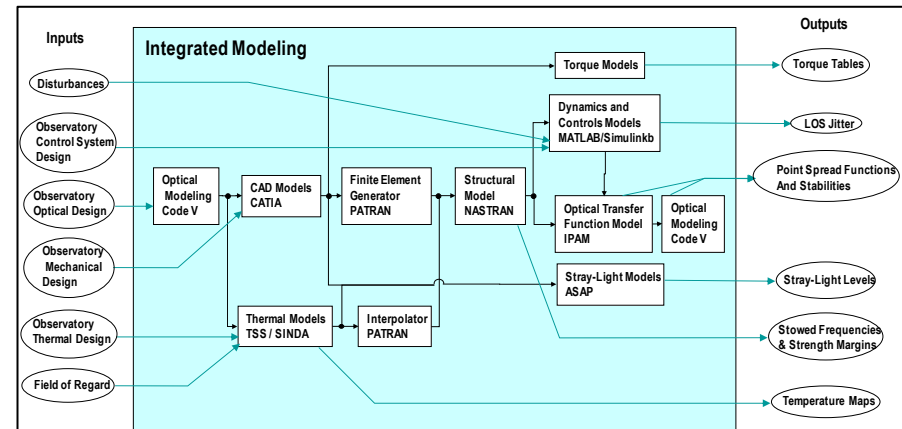



Risk and Issue Management

- Systems Engineering is responsible for communicating / informing Project Management of current and impending Risks and Issues. Risks have a formal system. Issue methods are more tailored to the Project. (See figures below).
- An Issue is something that is certainly a problem and MUST be solved.
- Risk is an uncertainty with a “bad” potential outcome. (Unlike Issues, some Risks can be accepted)
 - Usually rated in two dimensions (Probability of Occurrence and Consequence) each on a scale of 1 to 5
- Risks can be categorized as “Technical”, “Cost” or “Schedule”, and the clear distinction between them is often very blurry. Rating criteria for each are slightly different.
- Systems Engineering is a key participant in the Risk Management Process. (Program Management usually chairs the Risk Board)
- Risk mitigation plans are formulated to lower high risks to levels acceptable for flight. Plans usually consist of a combination of:
 - Elimination
 - Transfer
 - Research (Technology Development can fall under this category)
 - Acceptance

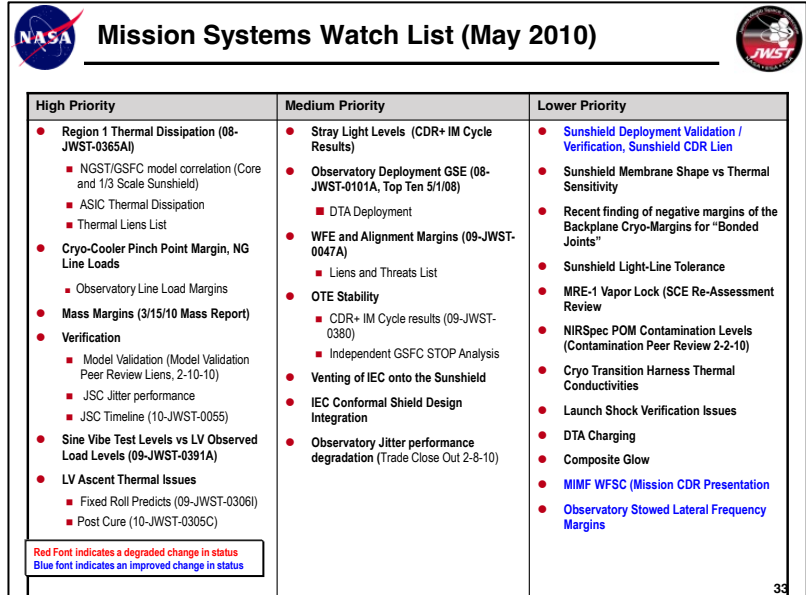
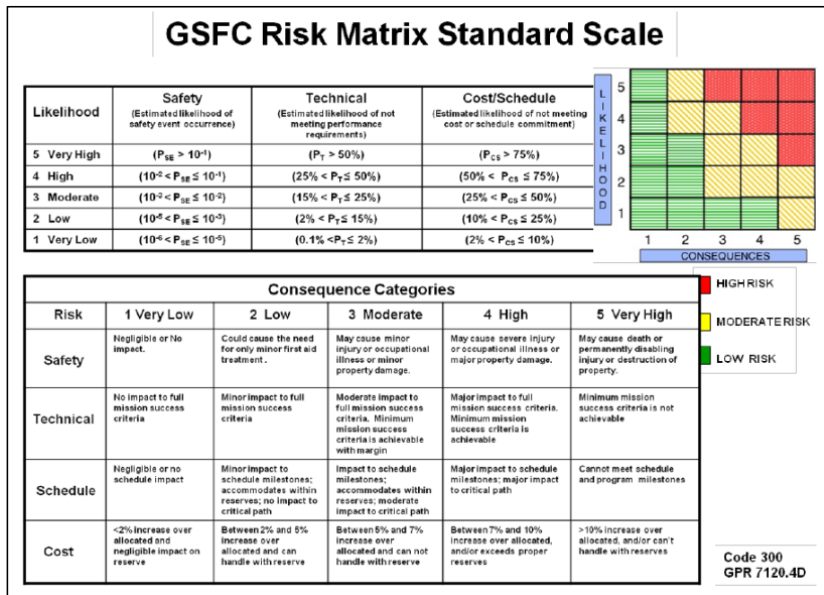



Verification (1 of 2)

- **Verification is the process that determines the “As-Built System” meets requirements and is ready to be deployed (Flight-Worthy)**
- **Verification is a “Bottom-Up” process. Verification of low level “child” requirements occurs first so that the part can proceed to the next level of integration. (Uses the Trail of Breadcrumbs from Requirements Flow Down)**
- **Requirement verification methods: Test, Similarity, Demonstration, Analyses**
- **Test (aka Test as You Fly) is usually the most reliable method. But for complex systems test as you fly may be either impractical or introduce more uncertainty than analysis.**
- **For these cases, a combination of Test and Analysis is employed:**
 - Tests to ensure that the Analytical Models used for verification accurately depict the As-Built Hardware (HW) within the assumed uncertainties.
 - Analyses that analyze the system under predetermined flight conditions (Some set of nominal and bounding cases)
 - Workmanship Tests that prove the system is put together correctly and within tolerances assumed by the analyses.
 - See following chart.
- **NOTE: There is a distinction between “Qualification and Verification Testing”**
 - Qualification proves the design is capable of withstanding certain critical environments (most of the time Launch and Ascent). Subjects a Qualification Hardware to environments far above the flight levels. Qual HW are not flown.
 - Acceptance proves that the “To Be Flown” HW meets workmanship tolerances and is subjected to test levels just a little above flight.
 - Proto-Flight tests are a compromise where the To-Be Flown HW is subjected to environments high enough above flight levels to prove the design will work reliably but not high enough to compromise life.



Verification (2 of 2)

Verification Program for JWST Line of Sight Jitter

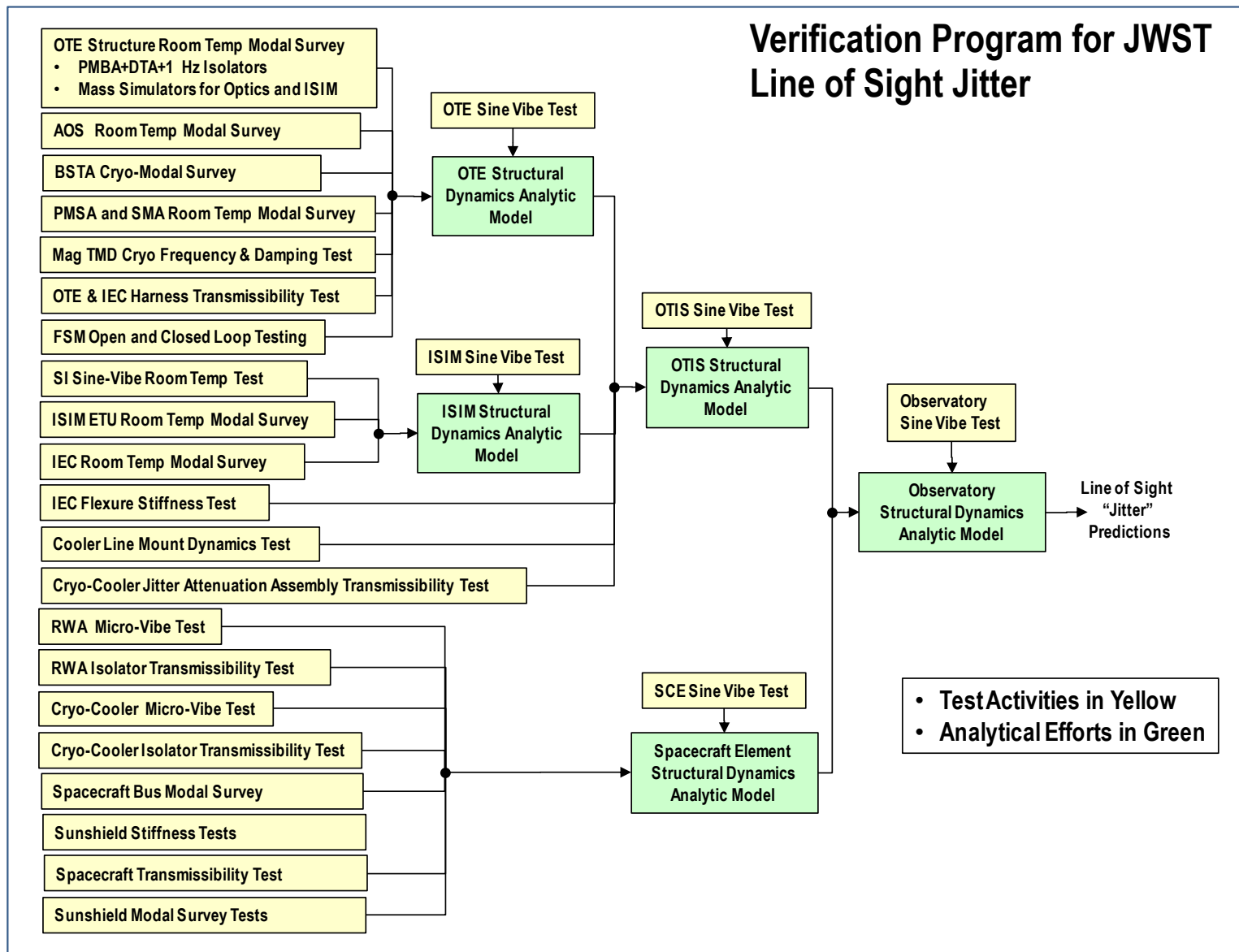

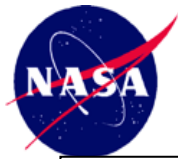

Systems Engineering Organization

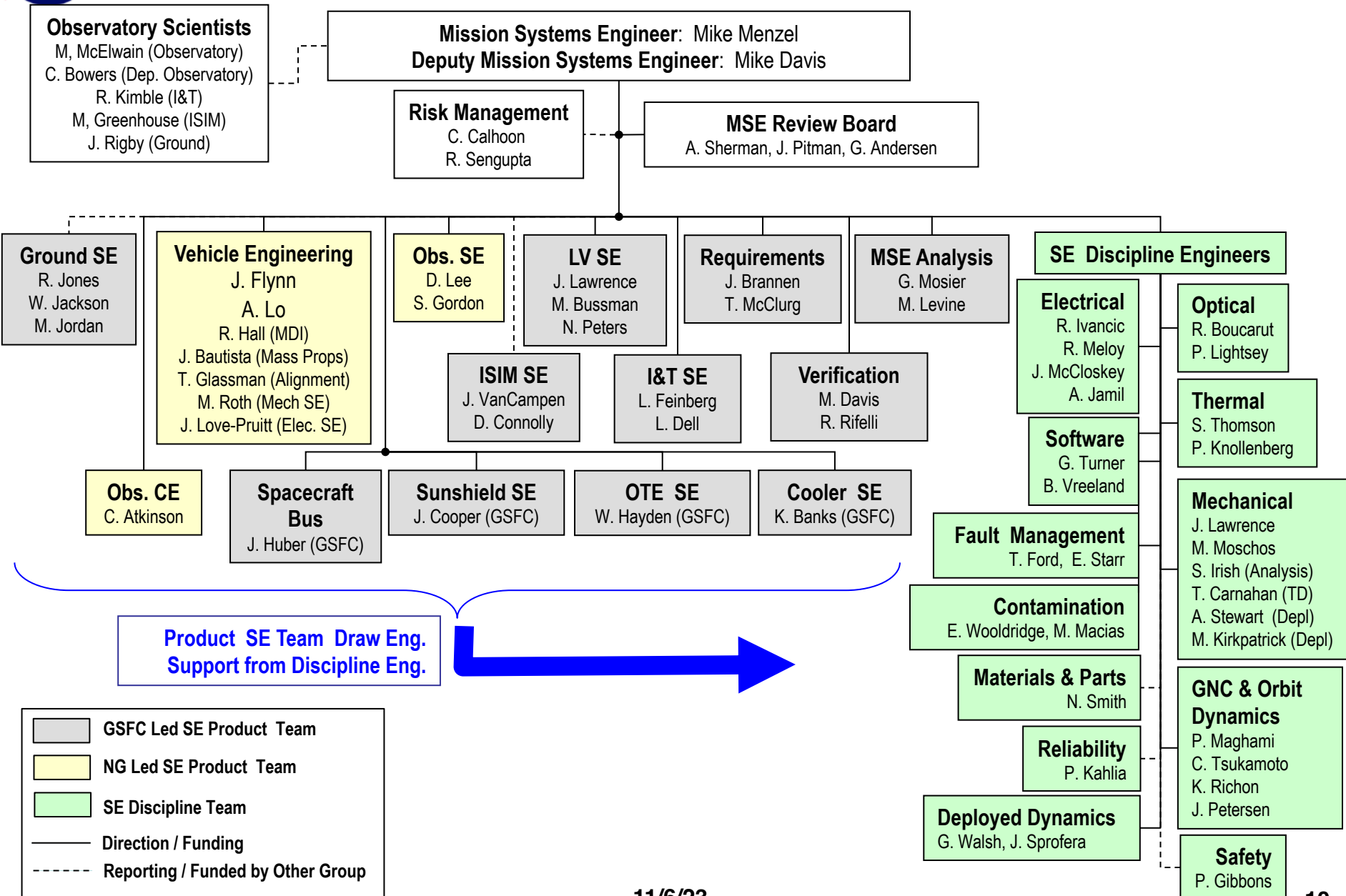

Product SE Team Draw Eng. Support from Discipline Eng.



- GSFC Led SE Product Team
- NG Led SE Product Team
- SE Discipline Team
- Direction / Funding
- - - - Reporting / Funded by Other Group



NASA Project Life Cycle

- The NASA Project Life Cycle is described in NASA Procedural Requirements (NPR) - 7120.5
- The cycle consists of series of independent engineering reviews to evaluate the readiness of the project to proceed to the next phase of development.
 - Usually reviewed by a Standing Review Board
 - Each review has specific entrance and success criteria
- These engineering reviews provide evaluations that inform the Key Decision Points (KDPs) that are gateways to proceed to the next official.
- The first of these reviews is the Mission Concept Review (MCR)

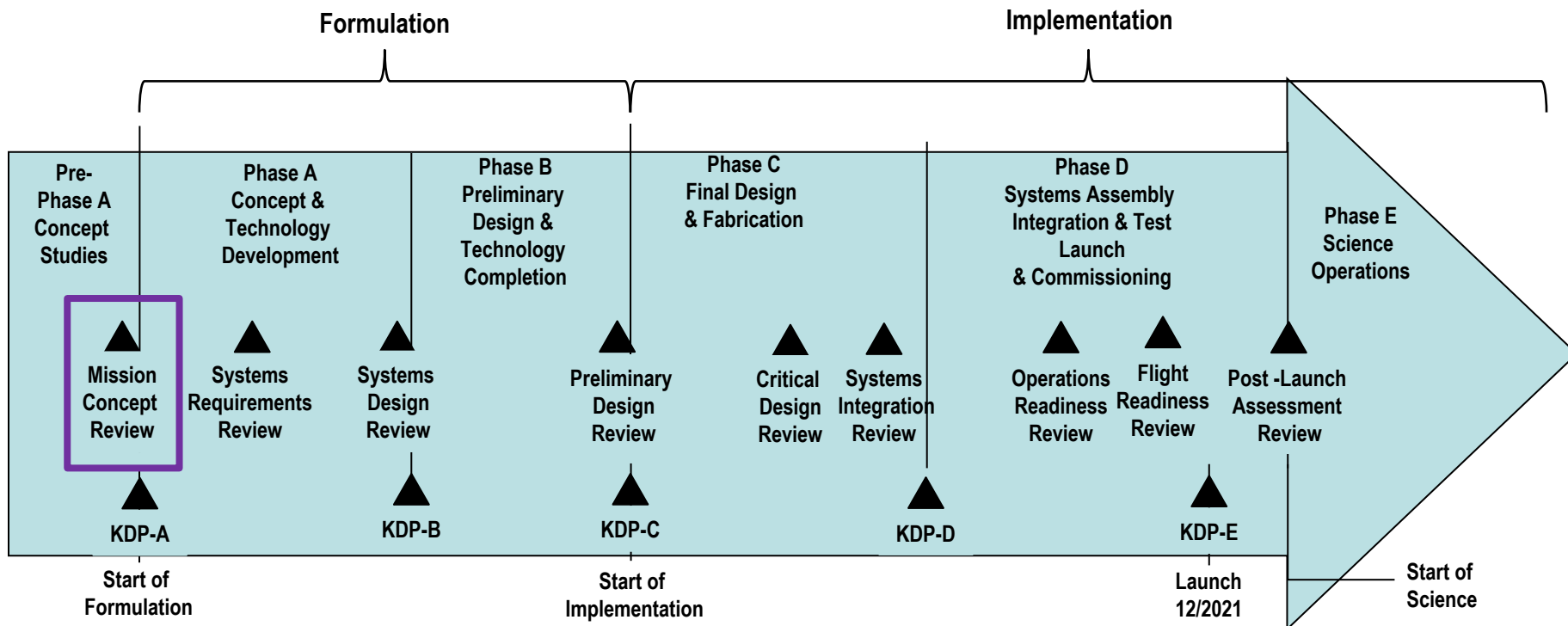



Mission Concept Review Definition

- **The MCR and its requirements are described in several NASA and GSFC documents:**
 - NPR 7120.5 Rev F: “NASA Space Flight Program and Project Management Requirements”
 - NPR 7123.1 Rev C: “NASA Systems Engineering Processes and Requirements”
 - GPR 7123.1 Rev C: “Goddard Procedural Requirements, Systems Engineering”
 - GSFC-STD-1001A “Criteria for Flight and Flight Support Systems Lifecycle Reviews”
- **Objective per NPR 7120.5 Rev F: To evaluate the feasibility of the proposed mission concept(s) and its fulfillment of the program's needs and objectives. To determine whether the maturity of the concept and associated planning are sufficient to begin Phase A.**



MCR Requirements via GSFC – STD – 1001A (1 of 2)

- **The MCR affirms the mission need and examines the proposed mission's objectives and the concept for meeting those objectives. Key technologies are identified and assessed. It is an internal review that is usually conducted by the system development organization. ROM budget and schedules are presented. At the MCR, the project demonstrates to the review panel that the:**
 - Proposed mission meets the science.
 - Objectives proposed mission is feasible.
 - Proposed mission and operations design concepts are viable.
 - Preliminary plan for lifecycle activities suitably illustrates reasonable execution of the mission within resource budgets and other foreseen constraints.
- **The MCR is normally held upon completion of mission feasibility studies and represents the conclusion of project pre-formulation activities.**
- **The MCR is usually chaired by the Standing Review Board (SRB).**



Draft Project Roadmap to MCR

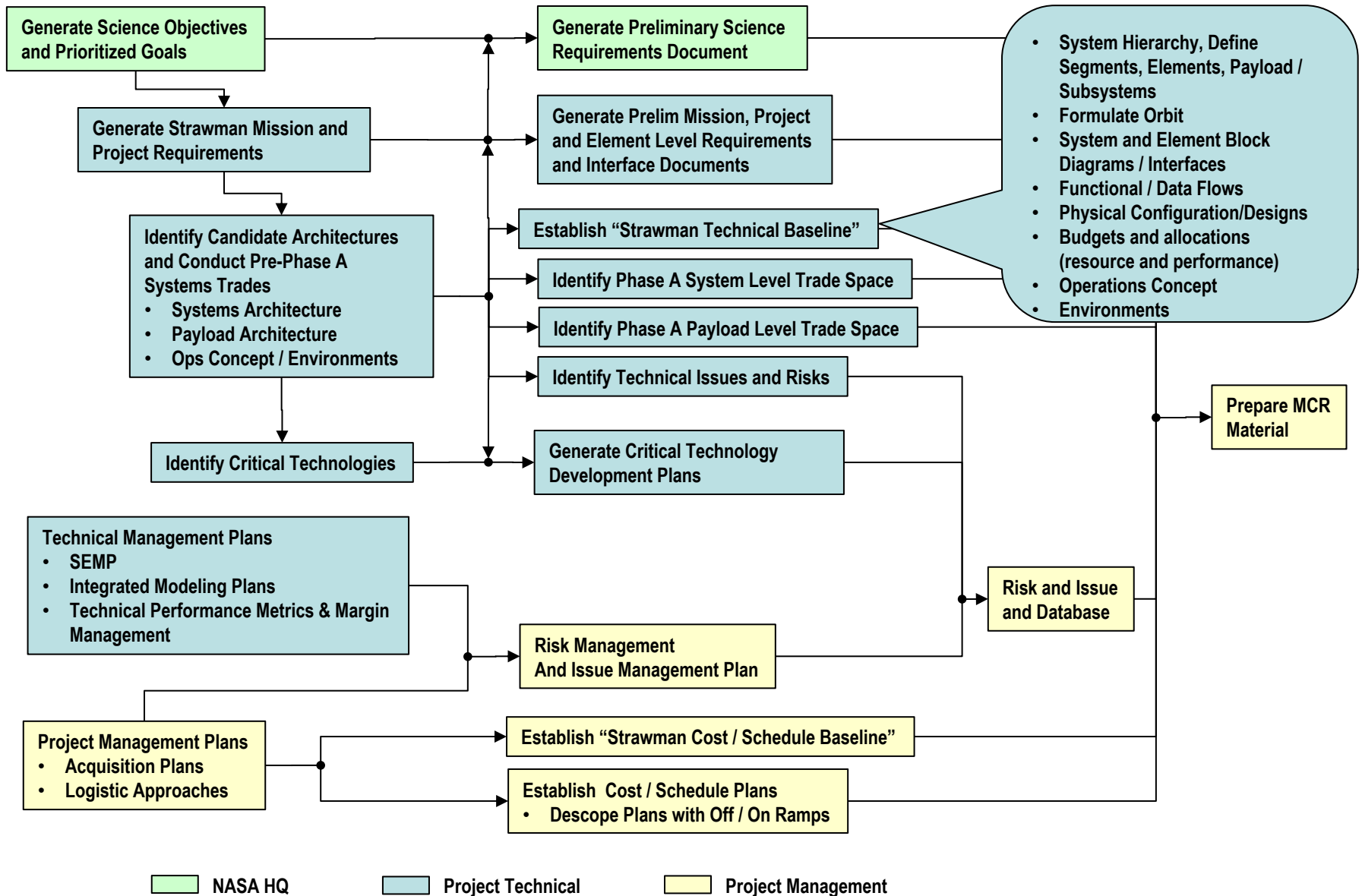



Summary

- **The MCR / KDP-A is a gateway review to start Phase A.**
- **The Roadmap to an MCR should provide the evidence that the science objectives can be met with a feasible / viable design.**
 - The existence of a strawman solution (technical, cost and schedule) can provide this.
 - The strawman will not be a final and or optimized solution, but just a tool. A point of departure for the proposed Phase A trade studies.
 - A critical viable Technology Development Plan shows the technologies can be developed in time to support the project.
 - A list of risks and or issues and their mitigation plans shows the identified risks and issues can be solved in time to support the project.
- **The Roadmap should establish that Project and Engineering plans are executable using preliminary and or initial versions of these documents.**