

TECHNOLOGY SOLUTION

Optics

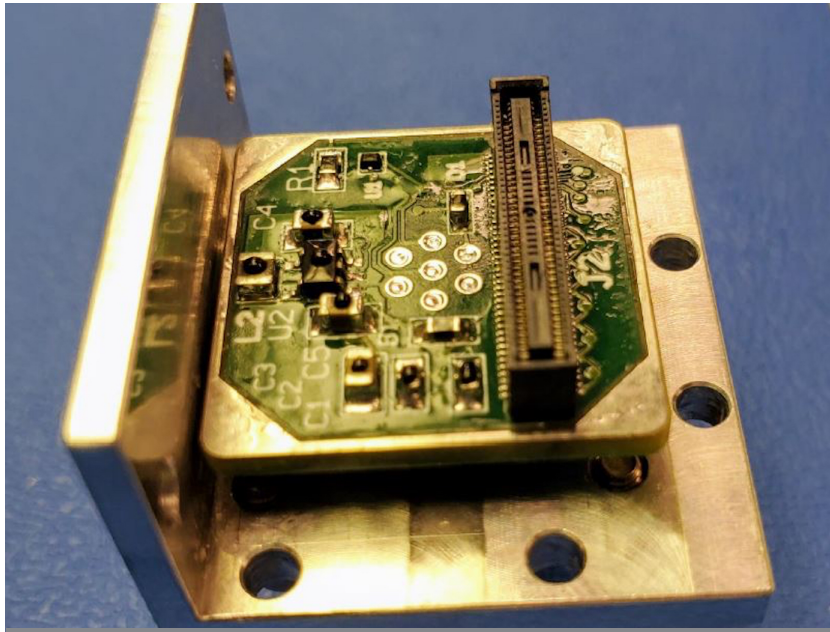

Ruggedized Infrared Camera

High Vibration and Harsh Environment Operation

Innovators at the NASA Marshall Space Flight Center have developed a ruggedized infrared (IR) camera system for harsh environments. The new technology is a space-rated IR camera assembly based on a FLIR Systems Boson® camera core. Advanced modifications allow the camera to survive high-vibration environments (e.g., launch) and improve heat removal for operation in a range of harsh conditions including vacuum. Designed for NASA use in Earth orbit and beyond, the camera has a combination of characteristics not currently available in commercial camera offerings. The IR camera assembly has been fully tested and qualified for operation in extreme conditions including high vibration, shock, vacuum, and temperature cycling. Although designed for space applications, the assembly may also be valuable for harsh environment terrestrial uses.

BENEFITS

- Low cost: combines multiple standard components with a custom printed circuit board and mount to create a package suitable for demanding applications
- Small and lightweight: the complete assembly, including camera core and lens, is less than 8 in³ and weighs 0.36 lbs
- Enhanced operability: allows a standard IR camera to function in extreme environments
- Compatibility: custom electronics support the USB standard, allowing plug-and-play communication with external computers
- Robust: the use of a military grade connector, rugged printed circuit board, sturdy aluminum mount, and conductive cooling system allows the unit to survive in launch environments and operate in vacuum



THE TECHNOLOGY

This new technology applies NASA engineering to a FLIR Systems Boson® camera core to enable a robust IR camera for use in space and other extreme applications. Enhancements to the standard Boson® platform include a ruggedized housing, connector, and interface. The Boson® is a COTS small, uncooled, IR camera based on microbolometer technology and operates in the long-wave infrared (LWIR) portion of the IR spectrum. It is available with several lens configurations. NASA's modifications allow the IR camera to survive launch conditions and improve heat removal for space-based (vacuum) operation. The design includes a custom housing to secure the camera core along with a lens clamp to maintain a tight lens-core connection during high vibration launch conditions. The housing also provides additional conductive cooling for the camera components allowing operation in a vacuum environment. A custom printed circuit board (PCB) in the housing allows for a USB connection using a military standard (MIL-STD) miniaturized locking connector instead of the standard USB type C connector. The system maintains the USB standard protocol for easy compatibility and "plug-and-play" operation.

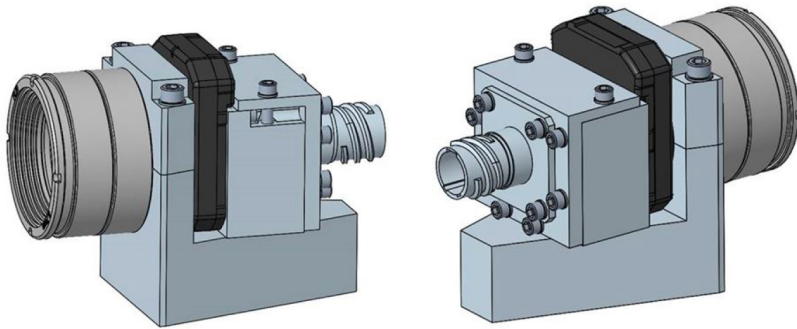

A rendering of NASA's connector and mount assembly with the FLIR Boson® camera core and lens. The enclosure with the connector contains the custom printed circuit board.

APPLICATIONS

The technology has several potential applications:

- Satellites and spacecraft: imaging systems for satellites in LEO, including SmallSats, CubeSats, and other spacecraft
- Aerospace: aircraft-mounted IR cameras for surveillance and thermal analysis of aircraft engines
- First responders: night vision and enhanced imaging capability in fog, rain, and smoke for search and rescue, firefighting, threat detection, and surveillance
- Military: IR cameras requiring high tolerance to vibration
- Unmanned vehicles: collision avoidance systems
- Automotive: vision systems for autonomous vehicles
- Industrial machinery: process control and quality control
- Consumer goods: rugged IR cameras for outdoor use

PUBLICATIONS

Patent Pending

technology.nasa.gov

More Information

National Aeronautics and Space Administration

Agency Licensing Concierge

Marshall Space Flight Center

Huntsville, AL 35812

202-358-7432

Agency-Patent-Licensing@mail.nasa.gov

www.nasa.gov

NP-2021-01-2914-HQ

NASA's Technology Transfer Program pursues the widest possible applications of agency technology to benefit US citizens. Through partnerships and licensing agreements with industry, the program ensures that NASA's investments in pioneering research find secondary uses that benefit the economy, create jobs, and improve quality of life.

MFS-33948-1, MFS-TOPS-108